



**The University of Sydney  
Department of Civil Engineering  
Centre for Advanced Structural Engineering**

# **ColdSteel/4600**

**Version 1.0**

**Cold-Formed Steel Design to AS/NZS 4600:1996**

# **User's Manual**

**November 1998**

## Contents

<b>1</b>	<b>Introduction</b>	<b>2</b>
<b>2</b>	<b>Scope of Software</b>	<b>2</b>
<b>3</b>	<b>Program Operation</b>	<b>3</b>
<b>4</b>	<b>Design Examples</b>	<b>22</b>
<b>Appendix I.</b>	<b>The ColdSteel Database</b>	<b>48</b>
<b>Appendix II.</b>	<b>Section Properties</b>	<b>63</b>
<b>Appendix III.</b>	<b>Summary of Member Design Checks</b>	<b>66</b>
<b>Appendix IV.</b>	<b>Error and Warning Codes</b>	<b>70</b>
<b>Appendix V.</b>	<b>References</b>	<b>72</b>

The software described in this document is distributed under licence and may be used or copied only in accordance with the terms of such licence.

While every effort has been made to ensure its reliability, the authors are not liable for damages which result from the use or misuse of the software. The ultimate responsibility for checking and correctly interpreting the results rests with the user.

All queries should be directed to:

Dr Murray Clarke  
Department of Civil Engineering  
The University of Sydney  
NSW 2006  
Phone: 02 9351 2115  
Fax: 02 9351 3343  
Email: M.Clarke@civil.usyd.edu.au

© Centre for Advanced Structural Engineering, The University of Sydney, November 1998.

## 1 Introduction

**ColdSteel** is a computer program for the design of cold-formed steel structural members to the limit states Australian/New Zealand Standard AS/NZS 4600:1996 (SA/SNZ 1996). The program runs in a standalone interactive mode under the Windows 95/98/NT operating systems. **ColdSteel** is intended to be used as a cold-formed steel design “calculator” that facilitates the semi-automated design of cold-formed steel structural members by freeing the engineer from the complex detail of effective section, distortional buckling stress and other detailed design computations.

**ColdSteel** performs all the relevant member strength calculations for a range of commonly used cold-formed profile shapes including angle sections, channel sections, Z-sections, hat sections, rectangular hollow sections, and circular hollow sections. The program can run in either a “check” or “design” mode. For a given set of design actions and other relevant parameters such as effective lengths, running **ColdSteel** in check mode will determine if the member is satisfactorily designed to AS/NZS 4600:1996 with respect to all relevant strength limit states. The “load factor” and corresponding governing limit state is also reported. In design mode, **ColdSteel** determines the lightest section of a particular cross-sectional shape for which the design with respect to the given set of actions and other relevant parameters is satisfactory.

**ColdSteel** has extensive reporting and graphical visualisation facilities. For any particular check or design, **ColdSteel** provides a complete list of all cross-sectional properties for both the full and effective sections, all nominal and design member capacities, the load factor against failure for all relevant strength limit states, and other miscellaneous parameters such as elastic column buckling stresses, elastic beam lateral buckling moments, and distortional buckling stresses. The graphical capabilities of **ColdSteel** enable the visualisation of the effective sections in compression and in bending about both axes in both directions.

## 2 Scope of Software

**ColdSteel** is based on the design rules specified in AS/NZS 4600:1996 Cold-Formed Steel Structures (SA/SNZ 1996). Specifically, the following clauses of AS/NZS 4600:1996 are incorporated in the program:

### Section 1 — Scope and General

#### 1.6.2 Structural Analysis and Design

### Section 2 — Elements

- 2.1 Section properties
- 2.2 Effective Widths of Stiffened Elements
- 2.3 Effective Widths of Unstiffened Elements
- 2.4 Effective Widths of Uniformly Compressed Elements with an Edge Stiffener or One Intermediate Stiffener

### Section 3 — Members

- 3.1 General
- 3.2 Members Subject to Tension
- 3.3 Members Subject to Bending
- 3.4 Concentrically Loaded Compression Members
- 3.5 Combined Axial Load and Bending
- 3.6 Cylindrical Tubular Members

## Appendix D — Distortional Buckling Stresses of General Channels, Lipped Channels and Z-Sections in Compression and Bending

- D.1 General Channels in Compression
- D.2 Simple Lipped Channels in Compression
- D.3 Simple Lipped Channels or Z-Sections in Bending about the Axis Perpendicular to the Web

## Appendix E — Section Properties

- E.1 Shear Centre Distance ( $m$ ), Torsion Constant ( $J$ ) and Warping Constant ( $I_w$ )
- E.2 Monosymmetry Section Constants

## Appendix F — Unstiffened Elements with Stress Gradient

## 3 Program Operation

### 3.1 Main Form

After the initial title screen, the Main form of **ColdSteel** is displayed as shown in Fig. 1. The majority of the data that is required to perform a member strength check or design is displayed on the Main form. However, since some of the design actions may be zero, it may not be necessary to enter data for every input parameter. At all times, the relevant data items are clearly delineated, and the unnecessary items are shaded the same colour as the Main form. The Options form, instigated by clicking on the Options button of the Main form, enables a particular combination of length, force and mass units to be set, together with other parameters relating to calculation of compressive, lateral buckling and distortional buckling capacities. The Options form is discussed in detail in Section 3.2.

It will be observed from Fig. 1 that the relevant units are displayed beside each item of data in the Main form. If the system of units is changed through the Options form, then the units and data values displayed on the Main form alter correspondingly.

Fig. 1 Main form of **ColdSteel**

The physical problem represented by the data on the Main form shown in Fig. 1 corresponds to a C-20015 Grade 450 lipped channel section in uniform bending about the major ( $x$ ) axis as shown in Fig. 2. The span of the member is 6 m and it has lateral and torsional restraints at the supports and at midspan. The data required for **ColdSteel** comprises the following:

- effective lengths,  $L_{ey} = L_{ec} = 3$  m
- moment modification coefficient,  $C_{bx} = 1.0$
- design moment  $M_x^* = -5$  kNm

The above problem and data will constitute the basis of many of the figures presented in Section 3 of this User's Manual.

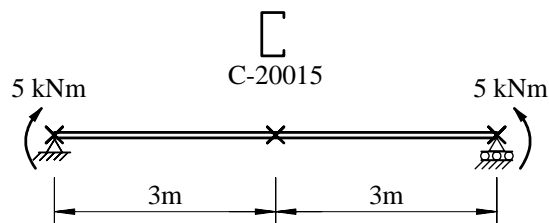

Fig. 2 Lipped channel section beam in uniform bending

The Main form comprises the data items described below.

### Section Class

The section class data is located in a list box immediately beside the Section label shown at the top-left of the Main form. Clicking on the arrow on the right-hand side of the section class list box reveals the full list of available section classes. The sections available in this version of **ColdSteel** are:

- Plain (unlipped) equal-angle section
- Plain (unlipped) unequal-angle section
- Plain (unlipped) channel section
- Lipped channel section
- Plain (unlipped) Z-section
- Lipped Z-section
- Plain (unlipped) hat section
- Plain (unlipped) hat section with an intermediate V-stiffener in the top flange
- Lipped hat section
- Lipped hat section with an intermediate V-stiffener in the top flange
- Square hollow section
- Rectangular hollow section
- Circular hollow section.

The basic profile shapes of these sections are shown in Fig. 3.

The above section classes are displayed graphically and may be selected from an icon palette as shown in Fig. 4. The icon palette is visible if the Options/View Icon Palette menu item is checked, and is not visible if this item is unchecked. The icon palette may be moved and resized as convenient.

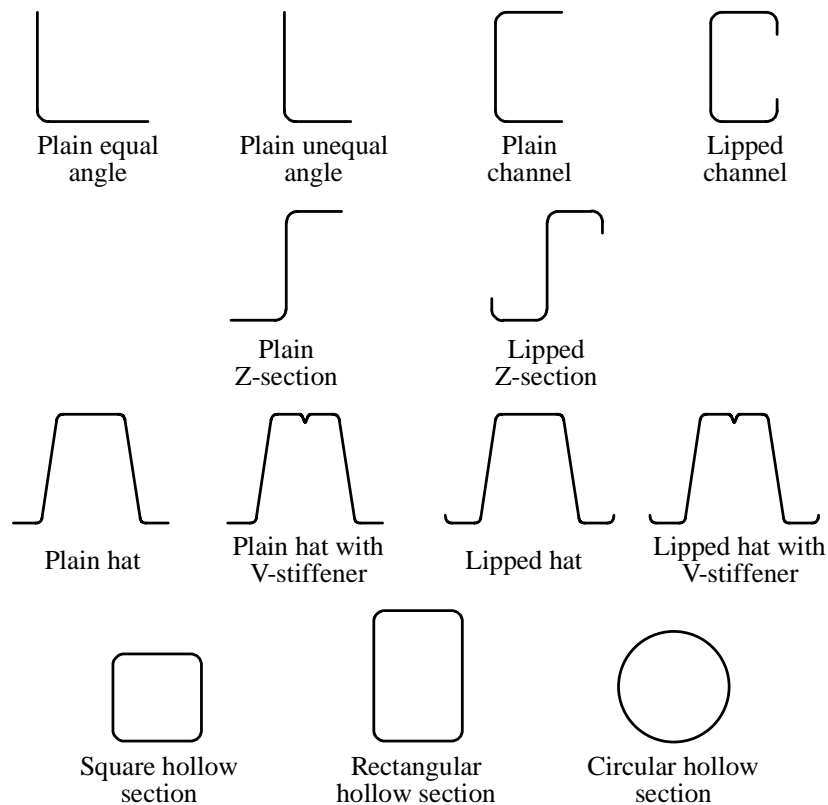

Fig. 3 Profile shapes incorporated into **ColdSteel**

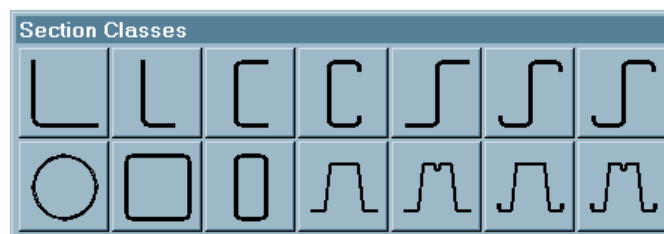

Fig. 4 **ColdSteel** section class icon palette

### Section Designation

For a particular chosen section class, a list of pre-defined section designations is available. The section designation is chosen from the list box located immediately below the Section Class list box. Clicking the arrow on the right-hand side of the section designation list box displays the full list of available profiles for the chosen section class. It is possible for users to customise their own section designations, and this is performed by modifying the **ColdSteel** database as described in Appendix I.

### Material Grade

The Material Grade list box, located beside the Material label, may be disabled or enabled depending on whether the Use Default Material option is checked or not. If the Use Default Material option is checked, the Material Grade list box is disabled and the material displayed corresponds to that specified for the current section designation in the **ColdSteel** database. If the Use Default Material option is unchecked, the Material Grade list box is enabled and the user can select from the list of available materials. The available

materials are specified in the [Material] section of the **ColdSteel** database as described in Appendix I. It is possible for the user to define their own materials.

### Axis System

For some cross-sectional shapes, such as Z-sections and angle sections, the principal ( $x$ - $y$ ) axes are rotated from the so-called non-principal or "rectangular" ( $n$ - $p$ ) axes yet it is often the case that such members are constrained to bend about a non-principal axis. For example, Z-section purlins attached to sheeting are usually constrained to bend about an axis perpendicular to the web (the  $n$ -axis). **ColdSteel** then uses a stress distribution based on this assumption to calculate the effective sections in bending. In **ColdSteel**, the Axis System option will only be enabled if the currently chosen section class is one for which it is relevant to consider bending about non-principal ( $n$ - $p$ ) axes. If the  $n$ - $p$  axis system is chosen, the subscripts on the design actions and equivalent moment coefficients displayed on the main form alter from  $x$  to  $n$  and  $y$  to  $p$  accordingly.

### Design Actions

Clause 1.6.2 *Structural Analysis and Design* of AS/NZS 4600:1996 does not mention whether the design actions should be based on first-order or second-order elastic analysis. However, the terms  $C_{mx}/\alpha_{nx}$  and  $C_{my}/\alpha_{ny}$  in the member strength interaction equation for combined compression and bending in Section 3.5.1 of AS/NZS 4600:1996 function as amplification factors and so it is evident that first-order design moments are implied.

Through the Options/General form, **ColdSteel** provides the user with the option of specifying whether the design actions employed have been calculated from first or second order elastic analysis. In the latter case, **ColdSteel** sets the moment amplification factors  $C_{mx}/\alpha_{nx}$  and  $C_{my}/\alpha_{ny}$  to be unity in the appropriate interaction equations. This approach seems reasonable (Hancock 1998) but it should be noted that further research is required in this area for cold-formed members.

In **ColdSteel**, the design actions comprise the axial force, the bending moments about both cross-section axes, the shear forces parallel to both cross-section axes, and the bearing force parallel to the vertical axis. It should be noted that for any particular member strength check or design, some of the design actions may (and invariably will) be zero. The bending moments, shear forces and bearing force are defined with respect to the chosen axis system (principal or non-principal). In the following description it will be assumed that the design actions relate to the principal ( $x$ - $y$ ) axes rather than the non-principal ( $n$ - $p$ ) axes.

#### Design axial force ( $N^*$ )

The design axial force ( $N^*$ ) is the maximum axial force in the member caused by the factored nominal loads, and is assumed positive when tensile and negative when compressive.

#### Design moments ( $M_x^*$ and $M_y^*$ )

The design bending moments ( $M_x^*$  and  $M_y^*$ ) correspond to the maximum moments about the  $x$  and  $y$  axes caused by the factored nominal loads. As discussed above, these moments should be derived from first-order elastic structural analysis and should therefore not include second-order effects. Furthermore, the sign of the moments may be input as positive or negative, with the positive sign convention following the right-hand rule as shown in Fig. 5. Positive moments  $M_y^*$ , for example, cause compression on the tips of the flanges of the channel section depicted in Fig. 5.

Where a compressive axial force coexists with bending, the design moments ( $M_x^*$  and  $M_y^*$ ) input to **ColdSteel** should be based on the following assumptions:

- the line of action of the axial force corresponds to the full-section centroid;
- any eccentricity which may exist between the centroid of the full section and the centroid of the effective section (subjected to a uniform compressive stress  $f_n$ ) is ignored.

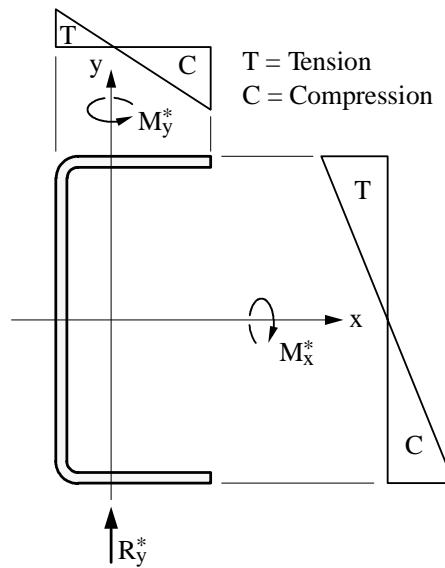

Fig. 5 Positive sign convention for design moments  $M_x^*$  and  $M_y^*$ , and bearing force  $R_y^*$

It should not be interpreted from the second of the above two assumptions that it is always appropriate to ignore the eccentricity between the centroids of the full and effective sections in capacity calculations when a compression force is involved. Indeed, one of the subtleties in cold-formed design is that the nominal column strength ( $N_c$ ) is computed based on the assumption that the design axial compression ( $N^*$ ) acts through the effective-section centroid (computed for the cross-section subjected to a uniform compressive stress  $f_n$ ) rather than the full-section centroid. However, users of **ColdSteel** are shielded from the details of effective centroids and associated force eccentricities through the “Assumed line of action of compressive  $N^*$ ” option from within the Options form (see Section 3.2). If the compressive force is assumed to act through the effective-section centroid, then there is no eccentricity and no additional moments are computed internally by **ColdSteel**. If the compressive force is assumed to act through the full-section centroid, then there may be an eccentricity in which case appropriate additional moments are computed internally by **ColdSteel** and considered in capacity calculations.

#### Design shear forces ( $V_x^*$ and $V_y^*$ )

Design shear forces  $V_x^*$  and  $V_y^*$  are assumed to act in both the  $x$  and  $y$  directions, respectively, but it is not required to distinguish between positive and negative values.

#### Design bearing force ( $R_y^*$ )

A bearing force ( $R_y^*$ ) is assumed to act in the  $y$  direction only, with the positive sign convention indicated in Fig. 5.

The sign conventions described above for axial forces, bearing forces and bending moments are necessary to enable **ColdSteel** to distinguish between tensile and compressive forces, the direction of bearing, and the direction of bending, the latter being important for non-symmetric sections. It should be understood, however, that in the member design checks detailed in Appendix III, it is only the *magnitude* and not the sign of the design actions that is important, i.e., all the design actions are tacitly assumed to be positive when applying the design equations detailed in Appendix III.

## Tension Factors

### Correction factor ( $k_t$ )

The correction factor ( $k_t$ ) is a factor which allows for the effects of eccentric or local end connections on the nominal tensile capacity of a member as governed by fracture through the net section (see Clause 3.2.2 of AS/NZS 4600:1996).

### Equivalent removed width ( $b_r$ )

The equivalent removed width ( $b_r$ ) corresponds to the length of the cross-section perimeter which is removed due to bolt holes. The equivalent removed width ( $b_r$ ) must be input by the user and should incorporate an appropriate allowance for staggered holes, if relevant. The net area ( $A_n$ ) is then computed by ColdSteel as  $A_n = A_g - b_r t$ , in which  $A_g$  is the area of the full section.

## Member Lengths

### Actual member length ( $L$ )

The actual member length ( $L$ ) corresponds to the physical length of the member between its connection to supports or other members. It is provided mainly for reference purposes but is also used to determine the  $L/1000$  eccentricity required for angle sections in compression (see Clause 3.4.1 of AS/NZS 4600:1996).

### Effective lengths ( $L_{ex}$ , $L_{ey}$ and $L_{ez}$ )

The flexural ( $L_{ex}$  and  $L_{ey}$ ) and torsional ( $L_{ez}$ ) effective lengths are used for the calculation of the elastic flexural or flexural-torsional buckling stress ( $N_{oc}$ ) for the member in compression, and for the elastic lateral buckling moments ( $M_{ox}$  and  $M_{oy}$ ) for the member in bending. The  $x$  and  $y$  axes correspond to the principal axes of the cross-section.

## $C_b/C_m$ Factors for Calculation of Elastic Lateral Buckling Moment ( $M_o$ )

The  $C_b$  and  $C_m$  factors are coefficients used in elastic lateral buckling moment ( $M_o$ ) calculations which account for the non-uniform distribution of bending moment along the length of the segment (see Clause 3.3.3.2). In AS/NZS 4600:1996, two methods of calculating  $M_o$  are provided, and these are described in Clauses 3.3.3.2(a) and 3.3.3.2(b).

It may be gleaned from the lateral buckling formulae given in Clause 3.3.3.2 that  $C_b \approx 1/C_m$ , but nevertheless AS/NZS 4600:1996 requires the use of  $C_b$  in some lateral buckling moment calculations and  $C_m$  in others. The choice of whether  $C_b$  or  $C_m$  should be used depends on whether or not the cross-section has an axis of symmetry in the plane of bending, as indicated in Table 1.

Table 1. Relevant Bending Moment Coefficients based on Cross-Sectional Geometry

Cross-Sectional Geometry	Coefficient used for Calculation of	
	$M_{ox}$	$M_{oy}$
Doubly symmetric	$C_{bx}$	$C_{by}$
Singly symmetric about $x$ -axis	$C_{bx}$	$C_{my}$
Singly symmetric about $y$ -axis	$C_{mx}$	$C_{by}$
Point symmetry	$C_{bx}$	$C_{by}$
No axes of symmetry	$C_{mx}$	$C_{my}$

For calculation of the elastic lateral buckling moment  $M_{ox}$  for a member bent about the principal  $x$ -axis, the following procedures consistent with Clause 3.3.3.2 are used by **ColdSteel**:

- If the cross-section has an axis of symmetry about the  $x$ -axis,

$$M_{ox} = C_{bx} A r_{o1} \sqrt{f_{oy} f_{oz}} \quad (1)$$

- If the cross-section does not have an axis of symmetry about the  $x$ -axis,

$$M_{ox} = \frac{A f_{oy} \left[ (C_{sx} \beta_x / 2) + \sqrt{(\beta_x / 2)^2 + r_{o1}^2 (f_{oz} / f_{oy})} \right]}{C_{mx}} \quad (2)$$

In Eq. (2),  $\beta_x$  is the monosymmetry section constant defined by

$$\beta_x = \frac{1}{I_x} \int_A (x^2 y + y^3) dA - 2y_o \quad (3)$$

where  $y_o$  is the shear centre position relative to the centroid, and  $C_{sx}$  is a coefficient which is equal to  $\pm 1$  depending on the direction of bending about the  $x$ -axis.

For the calculation of the elastic lateral buckling moment  $M_{oy}$  for a member bent about the principal  $y$ -axis, the following procedures consistent with Clause 3.3.3.2 are used by **ColdSteel**:

- If the cross-section has an axis of symmetry about the  $y$ -axis,

$$M_{oy} = C_{by} A r_{o1} \sqrt{f_{ox} f_{oz}} \quad (4)$$

- If the cross-section does not have an axis of symmetry about the  $y$ -axis,

$$M_{oy} = \frac{C_{sy} A f_{ox} \left[ (\beta_y / 2) + C_{sy} \sqrt{(\beta_y / 2)^2 + r_{o1}^2 (f_{oz} / f_{ox})} \right]}{C_{my}} \quad (5)$$

In Eq. (5),  $\beta_y$  is the monosymmetry section constant defined by

$$\beta_y = \frac{1}{I_y} \int_A (y^2 x + x^3) dA - 2x_o \quad (6)$$

where  $x_o$  is the shear centre position relative to the centroid, and  $C_{sy}$  is a coefficient which is equal to  $\pm 1$  depending on the direction of bending about the  $y$ -axis.

Caution is advised when using **ColdSteel** to calculate the lateral buckling capacities of hat sections bent about the horizontal (non-symmetry) axis. This is because there is a large monosymmetry section constant ( $\beta_x$ ) associated with hat sections, and the shear centre ( $y_o$ ) is eccentric from the section centroid. The lateral buckling moments for hat sections may differ by an order of magnitude between positive and negative bending, and there is also a strong load height effect. Neither of these factors is considered adequately in Clauses 3.3.3.2(a) or 3.3.3.2(b) of AS/NZS 4600:1996. In view of the preceding comments, it is recommended that elastic lateral buckling moments for hat sections be determined using a rational elastic buckling analysis (CASE 1997a), as it is only in this way that the effects of support conditions, moment distribution and load height can be considered with a degree of accuracy.

### **$C_m$ Factors for use in Interaction Formulae for Combined Compression and Bending**

When compression and bending co-exist, AS/NZS 4600:1996 requires the specification of coefficients  $C_{mx}$  and  $C_{my}$  which account for an unequal distribution of bending moment for bending about the  $x$  and  $y$ -axes of the cross-section, respectively. These  $C_m$  coefficients are additional to the  $C_m/C_b$  coefficients described above which are used in elastic lateral buckling moment calculations.

The values of these  $C_m$  coefficients are defined in Clause 3.5.1 as follows:

- For compression members in frames subject to joint translation (side-sway),

$$C_m = 0.85 \quad (7)$$

- For restrained compression members in frames braced against joint translation and not subjected to transverse loading between their supports in the plane of bending,

$$C_m = 0.6 - 0.4 \left( \frac{M_1}{M_2} \right) \quad (8)$$

where  $(M_1/M_2)$  is the ratio of the smaller to the larger moment at the ends of that portion of the member under consideration which is unbraced in the plane of bending. The end-moment ratio  $(M_1/M_2)$  is taken as positive if the member is bent in reverse curvature and negative if it is bent in single curvature.

- For compression members in frames braced against joint translation in the plane of loading and subject to transverse loading between their supports, the value of  $C_m$  may be determined by rational analysis. However, in lieu of such analysis, the following values may be used:

- ◇ For members whose ends are restrained,  $C_m = 0.85$ .
- ◇ For members whose ends are unrestrained,  $C_m = 1.0$ .

### Bearing Coefficients

For all cross-section classes included in **ColdSteel**, only a bearing force ( $R_y^*$ ) in the vertical direction is considered. The corresponding nominal bearing capacity ( $R_{by}$ ) is defined in Clause 3.3.6 of AS/NZS 4600:1996. The capacity factor  $\phi_w$  for bearing is equal to 0.75. The various parameters related to bearing capacity are depicted in Tables 3.3.6(1) and 3.3.6(2) of AS/NZS 4600:1996 which have been partly reproduced here as Fig. 6. The former table in AS/NZS 4600:1996 relates to profiles having single webs (e.g. channel sections), and the latter table relates to back-to-back channel sections and profiles with restraint against web rotation.

#### Bearing length ( $l_b$ )

The actual length of bearing for a bearing force ( $R_y^*$ ) is denoted  $l_b$ . For the case of two equal and opposite concentrated loads distributed over unequal bearing lengths,  $l_b$  should correspond to the smaller bearing length. Refer to Tables 3.3.6(1) and 3.3.6(2) of AS/NZS 4600:1996 or Fig. 6 for diagrams depicting bearing length.

#### Bearing parameter ( $c$ )

The bearing parameter ( $c$ ) corresponding to a bearing force ( $R_y^*$ ) is equal to the edge distance from the end of the beam to the commencement of the first bearing load as depicted in Tables 3.3.6(1) and 3.3.6(2), and Fig. 6.

#### Bearing parameter ( $e$ )

The bearing parameter ( $e$ ) corresponding to two opposing bearing forces ( $R_y^*$ ) is equal to the interior distance between the two forces as depicted in Tables 3.3.6(1) and 3.3.6(2) and Fig. 6.

It should be noted that if the distance  $e$  between opposing bearing loads is less than 1.5 times the web depth  $d_1$  as defined in Tables 3.3.6(1) and 3.3.6(2), then the bearing involves two opposite loads or reactions. If  $e > 1.5d_1$ , a single load or reaction is assumed to be involved.

Nomenclature	Type and Position of Load	Configuration
End One Flange (EOF)	Single load or reaction $c < 1.5 d_1$	
Interior One Flange (IOF)	Single load or reaction $c > 1.5 d_1$	
End Two Flange (ETF)	Two opposite loads or reactions $c < 1.5 d_1$ $e < 1.5 d_1$	
Interior Two Flange (ITF)	Two opposite loads or reactions $c > 1.5 d_1$ $e < 1.5 d_1$	

Fig. 6 Definitions of parameters used in bearing capacity calculations

### 3.2 Options Form

The Options form enables the user to set several fundamental options which control the program operation and facilitate access to the more unusual or advanced features. The particular options which are available are grouped in the following categories:

- General Options
- Compression Options
- Bending Options
- Distortional Buckling Options

#### General Options

The General Options form is shown in Fig. 7. The options which can be set from this form are:

- **Units:** This option is used to set the units of length, force and mass which pertain to all calculations and reported values. The relevant unit of stress is derived from the specified units for length and force. If the units are changed, then all relevant input values are automatically scaled appropriately and the unit designations updated accordingly.
- **Design Actions:** This option is used to indicate whether the design actions (in particular the moments  $M_x^*$  and  $M_y^*$ ) have been determined using first-order or second-order elastic analysis. In the latter case,

**ColdSteel** sets the moment amplification factors  $C_{mx}/\alpha_{nx}$  and  $C_{my}/\alpha_{ny}$  to be unity in the appropriate member strength interaction equations.

- **ThinWall data file:** **ColdSteel** has the capability to generate an input file which can be utilised by the **ThinWall** software for cross-section stress and finite strip buckling analysis developed by the Centre for Advanced Structural Engineering at the University of Sydney (CASE 1997b). If the input field is non-blank, a **ThinWall** input file of the chosen name (which must end in “.dat”) is generated whenever a member strength check or design is performed by **ColdSteel**. The data written to the **ThinWall** file relates to the current cross-section, axis system and design actions. For example, if it is desired to undertake a **ThinWall** cross-section buckling analysis of a particular profile subjected to pure compression only, then a reference value of  $N$  of, say,  $-1$  kN should be used as input to **ColdSteel**, with all other design actions being specified as zero. Upon reading into **ThinWall**, the interactive data entry screens may be used to modify the data (e.g. the set of assumed buckling half-wavelengths) if required.

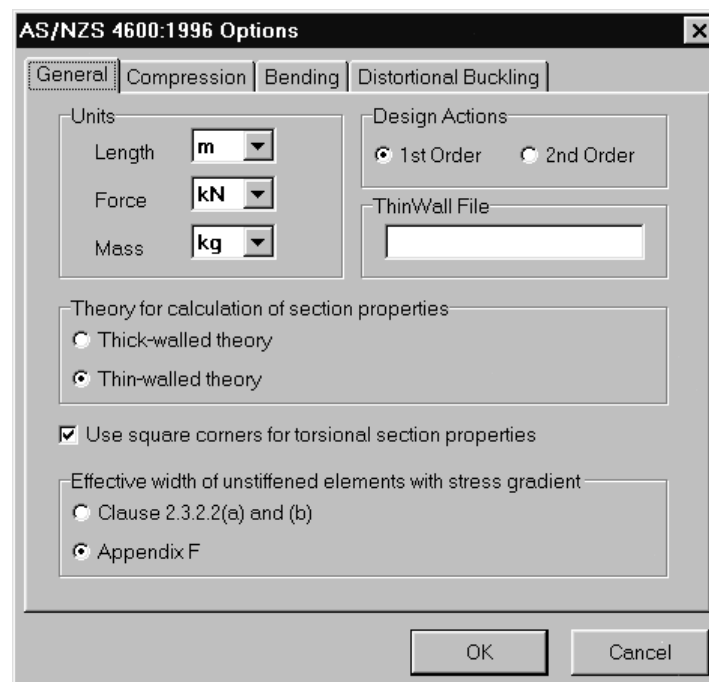

Fig. 7 General Options

- **Theory for calculation of section properties:** Flexural section properties such as second moments of area may be calculated using “thick-walled” or “thin-walled” theory. Thick-walled calculations include the second-moment of area of each element about its own centroidal longitudinal axis, whereas thin-walled theory neglects such terms. For thin sections, thick-walled theory and thin-walled theory give practically identical results. It is important to note that irrespective of whether the thick-walled or thin-walled theory option is chosen, *torsional* section properties such as St. Venant torsion constant, shear centre, warping constant and monosymmetry parameters utilise the thin-walled assumption universally.
- **Use “square” corners for torsional section properties:** If this option is checked then for the purposes of calculating the torsion-related section properties of shear centre ( $x_o$ ,  $y_o$ ), warping constant ( $I_w$ ), monosymmetry parameters ( $\beta_x$  and  $\beta_y$ ) and polar radius of gyration ( $r_{o1}$ ), a simplified model of the cross-section whereby the bends are eliminated and the section is represented by straight midlines is employed. A simplified model of this nature is permitted by Clause 2.1.2.1 of AS/NZS 4600:1996. If this option is not checked, then a “thin-walled” midline model in which the bends are modelled exactly is used. Primarily through its influence on the warping constant ( $I_w$ ), the use of a simplified “square corner” model rather than an accurate one which models the bends may lead to slightly improved values of design capacities which involve flexural-torsional or lateral buckling.

- **Effective width of unstiffened elements with stress gradient:** Clause 2.3.2.2 of AS/NZS 4600:1996 outlines the rules for the effective width of unstiffened elements and edge stiffeners for capacity calculations. These procedures implicitly assume that the element is subjected to a uniform compressive stress and do not consider the beneficial effect of a stress gradient on the resulting effective width. The effective width formulation described in Appendix F of AS/NZS 4600:1996 takes into account the effect of the stress gradient across the element and may be used to obtain greater section capacities.

### Compression Options

The Compression Options form is shown in Fig. 8. The options which can be set from this form are:

- **Assumed line of action of compressive  $N^*$ :** Clause 3.4.1 of AS/NZS 4600:1996 relating to concentrically loaded compression members states that “This Clause applies to members in which the resultant of all loads acting on the member is an axial load passing through the centroid of the effective section calculated at the critical stress ( $f_n$ ).” A corollary of this statement is that if the axial compression force is directed along the line of the full-section centroid, as indeed should be assumed when determining the design moments  $M_x^*$  and  $M_y^*$  to input to the Main form of **ColdSteel**, then additional bending moments resulting from the eccentricity (if it exists) of the full- and effective-section centroids should be considered in the internal design calculations performed by **ColdSteel**. It is up to the judgement of the engineer to ascertain whether it is more appropriate to assume the axial compression force acts through the full-section centroid or the effective-section centroid, however the following points are pertinent:
  - ◇ If the member is pin-ended at both ends then the effective centroid shift in a monosymmetric section has a strength degrading effect and should be considered in design. In this case, it should be assumed that the compressive force acts through the centroid of the full section, thus producing a possible eccentricity.
  - ◇ If the member is fix-ended at both ends then the effective centroid shift can be followed exactly by the external compression force and thus no additional moments are generated to degrade the strength of the member. In this case it is appropriate to assume that the compression force acts through the centroid of the effective section.
  - ◇ In a structural analysis program it is usually assumed that all members are connected concentrically through their elastic centroids. The axial compression force determined by such an analysis would then be tacitly assumed to act through the full-section centroid.
- **Calculation of elastic buckling load  $N_{oc}$ :** The column elastic flexural or flexural-torsional buckling load ( $N_{oc}$ ) is required to calculate the column strength. Ordinarily,  $N_{oc}$  is calculated from the given member effective lengths  $L_{ex}$ ,  $L_{ey}$  and  $L_{ez}$ . Alternatively, AS/NZS 4600:1996 permits the use of a rational elastic buckling analysis to calculate  $N_{oc}$  directly. If the latter option is chosen, the actual value of  $N_{oc}$  from the rational elastic buckling analysis should be input to **ColdSteel**.
- **Use  $L/1000$  eccentricity for angle sections:** This option is only relevant and only becomes operative if the current section is an equal or unequal angle. It implements the design provision of Clause 3.4.1 of AS/NZS 4600:1996 which states:
 

“Angle sections shall be designed for the design axial force ( $N^*$ ) acting simultaneously with a moment equal to  $N^*l/1000$  applied about the minor principal axis causing compression in the tips of the angle legs.”
- **Check distortional buckling in compression (Clause 3.4.6):** AS/NZS 4600:1996 Clause 3.4.6 suggests that the distortional buckling strength in pure compression should be considered for all sections for which it is a possible mode of buckling. However, it is stated in the commentary to AS/NZS 4600:1996 (AS/NZS 1998) that it is not normally necessary to check the distortional buckling mode of failure for simple lipped channels subjected to compression as they are already adequately designed for the distortional mode by virtue of Clause 2.4.3 for section capacity. On the other hand, some singly symmetric sections such as storage rack columns with additional rear flanges, are particularly sensitive to distortional buckling and in these cases Clause 3.4.6 is a very important design consideration. Due to

the degree of subjectivity associated with the distortional buckling strength check in pure compression, **ColdSteel** provides the user with the option of including or excluding it from the member strength calculations.

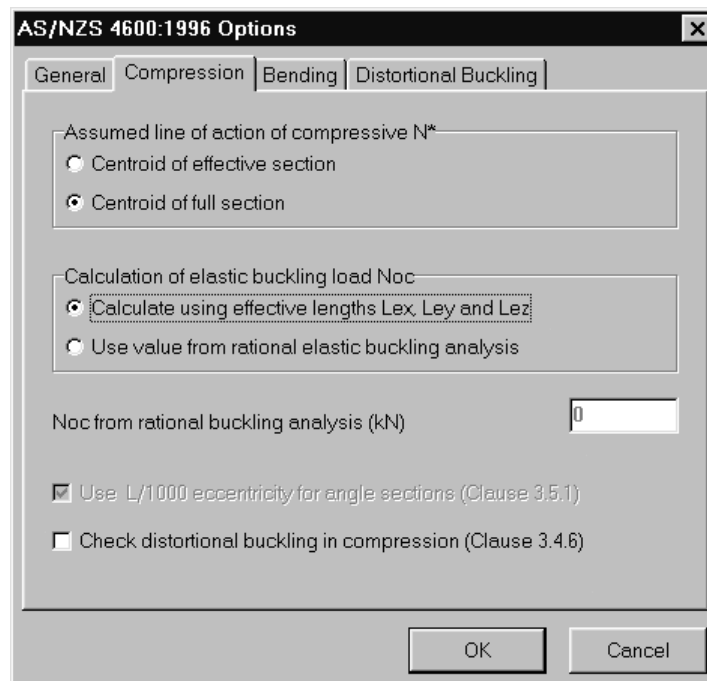

Fig. 8 Compression Options

### Bending Options

The Bending Options form is shown in Fig. 9. The options which can be set from this form relate to the determination of the lateral buckling moment capacity  $M_{bx}$  (Clause 3.3.3.2 of AS/NZS 4600:1996) for bending about the principal  $x$ -axis. The lateral buckling moment capacity ( $M_{bx}$ ) is a function of the critical moment ( $M_{cx}$ ) and the elastic buckling moment ( $M_{ox}$ ). It may be noted from the Bending Options form that different options are required to be set for the pure bending and the combined bending and compression strength checks. The main reason for this is that, according to the rules of AS/NZS 4600:1996, it is possible to determine  $M_{ox}$  using a rational elastic buckling analysis in the former case but not the latter.

The critical moment ( $M_{cx}$ ) can be calculated according to Clause 3.3.3.2(a) or 3.3.3.2(b). Clause 3.3.3.2(a) is applicable to all types of cross-sections, whether doubly-, singly-, point-, or non-symmetric. If it is chosen to calculate  $M_{cx}$  according to Clause 3.3.3.2(a), then the elastic lateral buckling moment ( $M_{ox}$ ) must also be calculated according to Clause 3.3.3.2(a).

According to AS/NZS 4600:1996, Clause 3.3.3.2(b) is strictly applicable only to channel or Z-sections bent about the centroidal axis perpendicular to the web. However, in **ColdSteel**, Clause 3.3.3.2(b) is also deemed appropriate for hat sections bent about the horizontal axis. The justification for extending the use of Clause 3.3.3.2(b) in this way is due to the caution which should be exercised when applying Clause 3.3.3.2(a) to hat sections bent about the horizontal axis (refer to the discussion of  $C_b/C_m$  factors in Section 3.1).

If it is chosen to calculate  $M_{cx}$  according to Clause 3.3.3.2(b), then the elastic lateral buckling moment ( $M_{ox}$ ) may be calculated according to the formulae given in Clause 3.3.3.2(a) or (b), or it may be determined from a rational elastic buckling analysis of the structural system. If the latter option is chosen, the relevant values of  $M_{ox}$  for positive and negative bending determined from such an analysis must be input to **ColdSteel**. For hat sections bent about the horizontal axis, it is recommended that the elastic buckling moments be determined from a rational elastic buckling analysis (CASE 1997a).

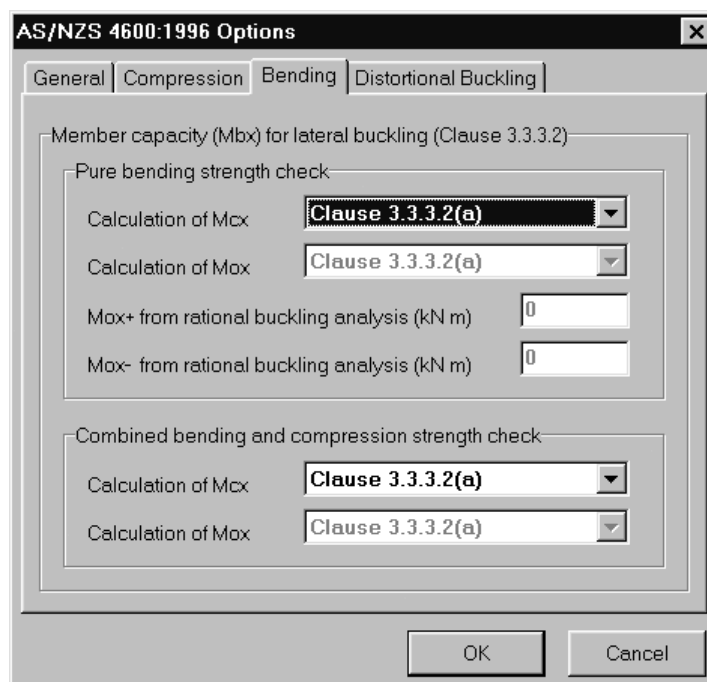

Fig. 9 Bending Options

### Distortional Buckling Options

For some sections, design against distortional buckling in pure compression (Clause 3.4.6) and/or bending (Clause 3.3.3.3) is required. The elastic distortional buckling stress in pure compression or bending can be calculated using a simple analytical model such as that given in Appendix D of AS/NZS 4600:1996 for flange distortional buckling, or that given by Serette & Peköz (1995) for web distortional buckling. Alternatively, a rational elastic buckling analysis of the whole plate assemblage, such as that performed by program **ThinWall** (CASE 1997b), can be used.

The Distortional Buckling Options form, shown in Fig. 10, enables the user to select whether the distortional buckling stresses in both compression and bending should be based on a simplified analytical model or a rational elastic buckling analysis of the complete plate assemblage. In **ColdSteel**, the simple model given in Appendix D is used for flange distortional buckling (for lipped channels and Z-sections, for example), while the model proposed by Serette & Peköz (1995) is used for the web distortional buckling of hat sections in bending about a horizontal axis. If the “simple analytical model” option is chosen, distortional buckling stresses are calculated “on-the-fly” as part of the member strength check. If the rational elastic buckling analysis option is chosen, the relevant distortional buckling stresses defined in the **ColdSteel** database are used in lieu of those calculated according to the simple analytical model. It is assumed that the distortional buckling stresses defined in the **ColdSteel** database have been previously calculated using **ThinWall** or a similar buckling analysis.

The distortional buckling options discussed above will only be enabled where they are relevant for the currently chosen cross-section. Also, the format for definition of distortional buckling stresses in the **ColdSteel** database will vary from profile to profile as outlined in Appendix I.

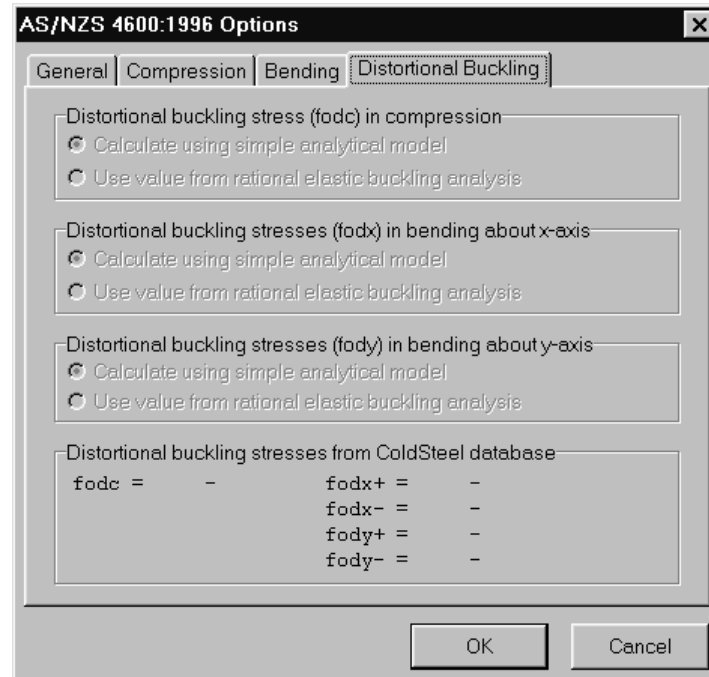

Fig. 10 Distortional Buckling Options

### 3.4 Checking the Strength of a Member

Clicking on the Check button from the Main form will instruct **ColdSteel** to perform a strength check using the currently chosen cross-section, material, design actions and other parameters. All relevant strength limit states specified in AS/NZS 4600:1996 are examined. The result of the strength check is displayed in summarised form in a window (Fig. 11) which indicates the cross-section class, designation and material, together with the governing "load factor" and the governing mode of failure.

The governing load factor ( $\lambda$ ) is the maximum scalar by which all the given design actions may be multiplied while still complying with all the strength design provisions of AS/NZS 4600:1996. That is, if the original design actions are represented by  $S^*$  and the design capacity by  $\phi R_u$ , then  $\lambda = \phi R_u / S^*$ . A value of the load factor ( $\lambda$ ) of at least unity indicate that the member has satisfactory strength.

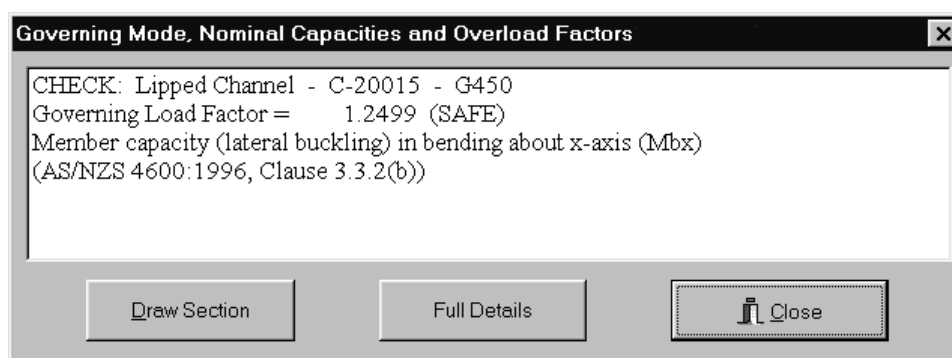

Fig. 11 Member strength check results form

### 3.5 Designing a Member

Clicking on the Design button on the Main form will instruct **ColdSteel** to perform a design using the currently chosen cross-section class, design actions and other parameters. The cross-section designations for the chosen cross-section class are ranked in order of mass per unit length and a strength check proceeds from the lightest to heaviest sections until a satisfactory design ( $\lambda \geq 1.0$ ) is attained (Fig. 12).

If the Use Default Material option is checked, then the material properties used in conjunction with each cross-section for which a design check is performed correspond to those defined in the **ColdSteel** database; the material designation may therefore vary from section to section during the design cycle. If the Use Default Material option is unchecked, then the currently chosen material is used for all design checks until the lightest satisfactory member is determined.

Section Designation	Material	Design Factor (LF)	Safety Status
C-10010	G450	0.15316	UNSAFE
C-10012	G450	0.18841	UNSAFE
C-10015	G450	0.25042	UNSAFE
C-15012	G450	0.46920	UNSAFE
C-10019	G450	0.34187	UNSAFE
C-15015	G450	0.66542	UNSAFE
C-20015	G450	1.24988	SAFE

Fig. 12 Member design results form

### 3.5 Visualisation of Full and Effective Sections

After a member strength check or design has been performed, the full and effective cross-sections can be visualised by clicking on the Draw Section button. A scaled drawing of the cross-section is shown together with a set of axes originating from the centroid of the full-section. A selection of the cross-section properties are also displayed in a smaller moveable window. A selection of buttons is available, the functions of which are as follows:

- Full Section button**—Draws the cross-section with the axes located at the full-section centroid ( $C$ ). The cross-section is orientated relative to the principal ( $x$ - $y$ ) or non-principal ( $n$ - $p$ ) axis system as appropriate. The cross-sectional properties of area ( $A$ ), second moments of area ( $I_{xx}$ ,  $I_{yy}$ ,  $I_{xy}$ ) and inclination of principal axes ( $\theta$ ) are shown in a smaller window (Fig. 13).
- Simplified Section button**—Draws the simplified model of the cross-section used for determination of torsional section properties, with the principal ( $x$ - $y$ ) axes originating from the full-section centroid ( $C$ ). The location of the shear centre is also shown and is labelled  $S$ . The cross-sectional properties of area ( $A$ ), second moments of area ( $I_{xx}$ ,  $I_{yy}$ ,  $I_{xy}$ ), inclination of principal axes ( $\theta$ ), shear centre location ( $x_o$ ,  $y_o$ ) and warping constant ( $I_w$ ) are shown in a smaller window (Fig. 14).
- Effective Section buttons**—A range of effective sections corresponding to different design capacities in compression and bending can be displayed. Note that for the purpose of calculating some effective section properties, the shape of some elements within the cross-section profile may be simplified. This is reflected in the graphical depiction of the various effective section models. The ineffective portions of the cross-section are shown highlighted in yellow. The origin of the axes is the full-section centroid, but the labelled centroid ( $C$ ) corresponds to the effective section currently displayed. The effective area ( $A_e$ ) and second moments of area ( $I_{xxe}$ ,  $I_{yye}$ ,  $I_{xye}$ ) and the maximum stress ( $f_{max}$ ) in the cross-section are displayed in a smaller window.

- ◇ **Ns button** Displays the effective section corresponding to the section strength in pure compression (uniform stress of  $f_y$ ) (Fig. 15).
  - ◇ **Nc button** Displays the effective section corresponding to the member (flexural or flexural-torsional buckling) strength in pure compression (uniform stress of  $f_n$ ) (Fig. 16).
  - ◇ **Msx+ button** Displays the effective section corresponding to the section strength in pure bending about the positive  $x$ -axis (maximum extreme fibre stress of  $f_y$ ) (Fig. 17).
  - ◇ **Mblx+ button** Displays the effective section corresponding to the member (lateral buckling) strength in pure bending about the positive  $x$ -axis (maximum extreme fibre *compressive* stress of  $f_c = M_{cx+}/Z_{fx+}$ , see Clause 3.3.3.3) (Fig. 18).
  - ◇ **Msx- button** Displays the effective section corresponding to the section strength in pure bending about the negative  $x$ -axis (maximum extreme fibre stress of  $f_y$ ) (Fig. 19).
  - ◇ **Mblx- button** Display the effective section corresponding to the member (lateral buckling) strength in pure bending about the negative  $x$ -axis (maximum extreme fibre *compressive* stress of  $f_c = M_{cx-}/Z_{fx-}$ , see Clause 3.3.3.3) (Fig. 20).
  - ◇ **Msy+ button** Displays the effective section corresponding to the section strength in pure bending about the positive  $y$ -axis (maximum extreme fibre stress of  $f_y$ ) (Fig. 21).
  - ◇ **Mbly+ button** Displays the effective section corresponding to the member (lateral buckling) strength in pure bending about the positive  $y$ -axis (maximum extreme fibre *compressive* stress of  $f_c = M_{cy+}/Z_{fy+}$ , see Clause 3.3.3.3) (Fig. 22).
  - ◇ **Msy- button** Displays the effective section corresponding to the section strength in pure bending about the negative  $y$ -axis (maximum extreme fibre stress of  $f_y$ ) (Fig. 23).
  - ◇ **Mbly- button** Displays the effective section corresponding to the member (lateral buckling) strength in pure bending about the negative  $y$ -axis (maximum extreme fibre *compressive* stress of  $f_c = M_{cy-}/Z_{fy-}$ , see Clause 3.3.3.3) (Fig. 24).
- **Print button**—Prints out the information currently displayed in the window on a single page.

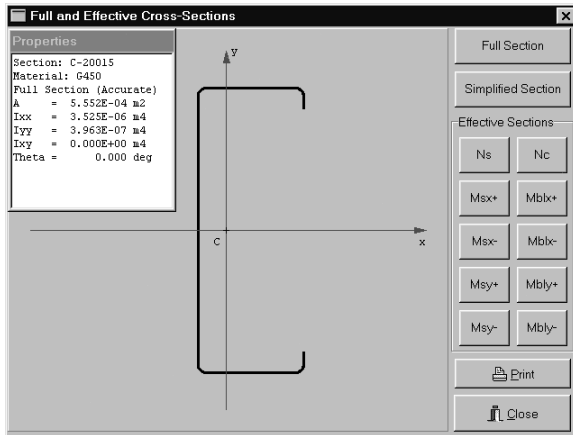

Fig. 13 Display after selecting the Full Section button

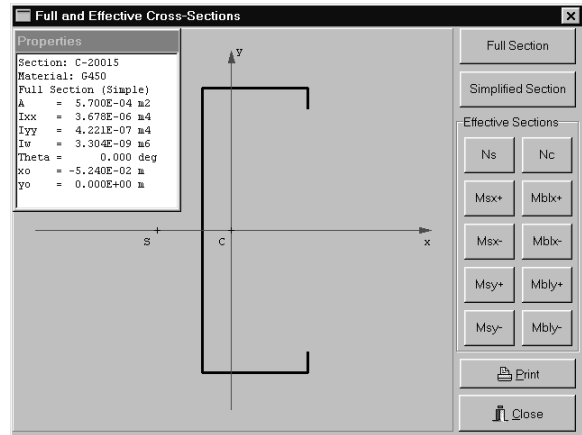

Fig. 14 Display after selecting the Simplified Section button

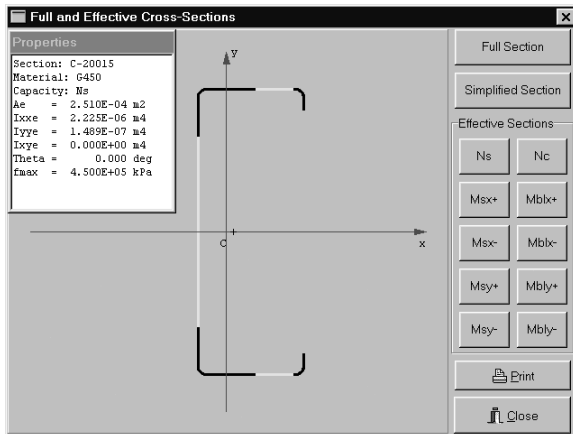

Fig. 15 Display after selecting the Effective Section Ns button

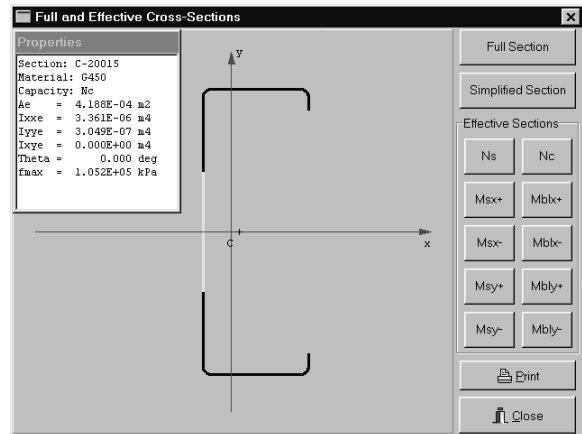

Fig. 16 Display after selecting the Effective Section Nc button

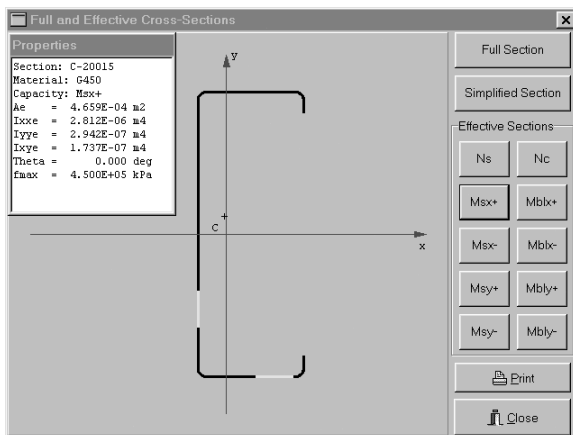

Fig. 17 Display after selecting the Effective Section Msx+ button

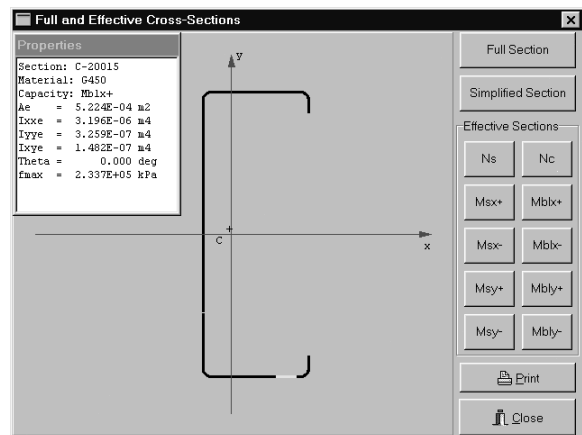

Fig. 18 Display after selecting the Effective Section Mblx+ button

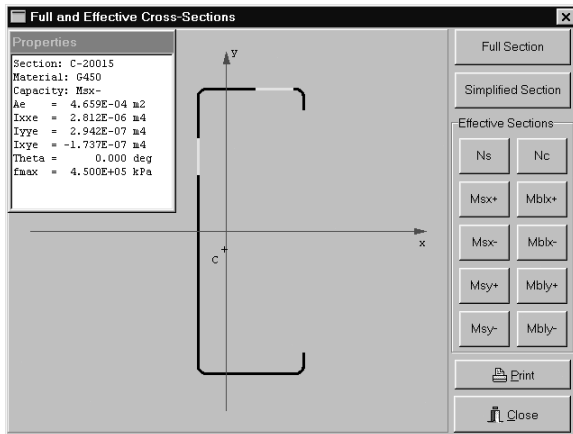

Fig. 19 Display after selecting the Effective Section M<sub>sx</sub>- button

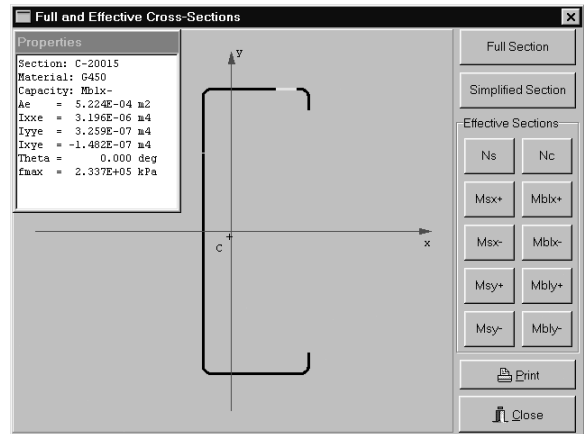

Fig. 20 Display after selecting the Effective Section M<sub>blx</sub>- button

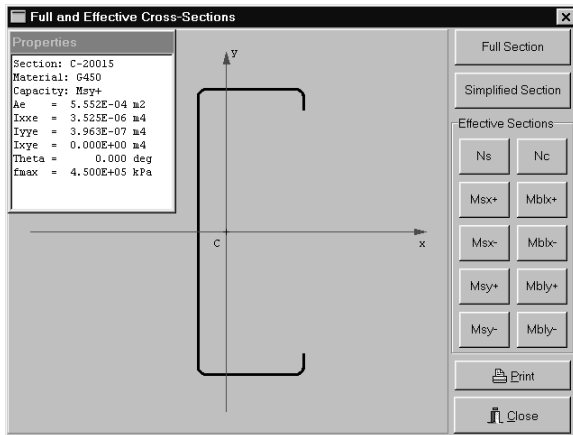

Fig. 21 Display after selecting the Effective Section M<sub>sy</sub>+ button

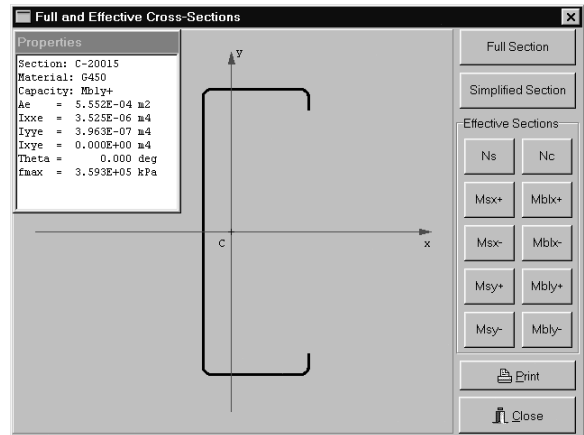

Fig. 22 Display after selecting the Effective Section M<sub>bly</sub>+ button

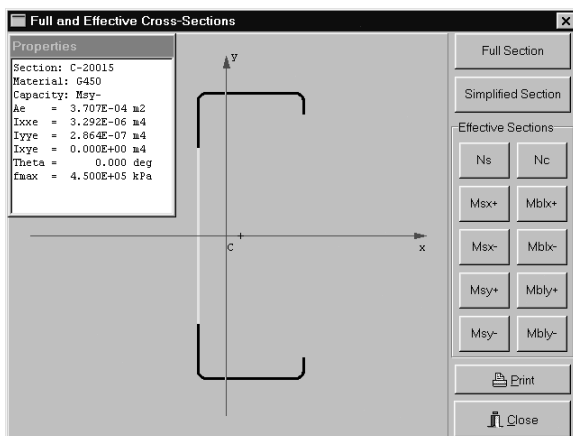

Fig. 23 Display after selecting the Effective Section M<sub>sy</sub>- button

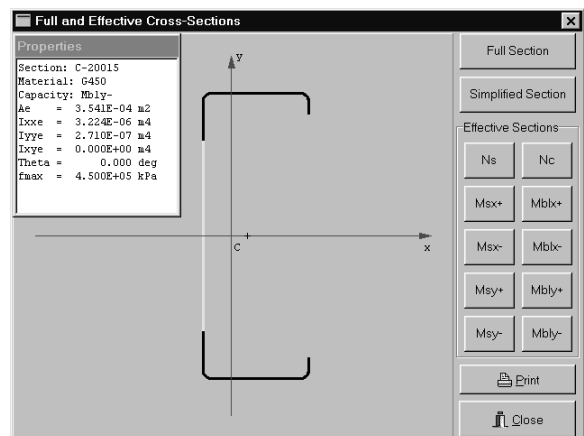

Fig. 24 Display after selecting the Effective Section M<sub>bly</sub>- button

### 3.6 Viewing Full Calculation Details

After a member strength check or design has been performed, a full report of all quantities calculated and all design checks conducted may be obtained by clicking on the Full Details button. A scrollable window with an extensive textual report is then displayed, as shown in Fig. 25. The full report can be printed directly to the printer using the Print button, or copied to the clipboard for later pasting into a text editor or word processor using the Copy to Clipboard button.

The report comprises the following sections:

- a summary of the cross-section class, designation and material;
- a summary of the governing load factor and the projected mode of failure;
- the units employed in all calculations;
- a reproduction of all relevant input parameters used for the member strength check/design;
- the overload factors for all strength limit states, with irrelevant strength limit states indicated by a dash [ - ];
- the *nominal* capacities for tension, compression, bending, shear and bearing;
- the *design* capacities for tension, compression, bending, shear and bearing, together with the relevant capacity ( $\phi$ ) factors;
- a reproduction of the cross-sectional dimensions, as provided in the **ColdSteel** database, that correspond to the section analysed;
- cross-sectional properties of the full section;
- selected effective cross-sectional properties for compression and bending capacities; and
- various miscellaneous parameters such as buckling stresses, lateral buckling moments, distortional buckling parameters, effective centroid shifts, etc.

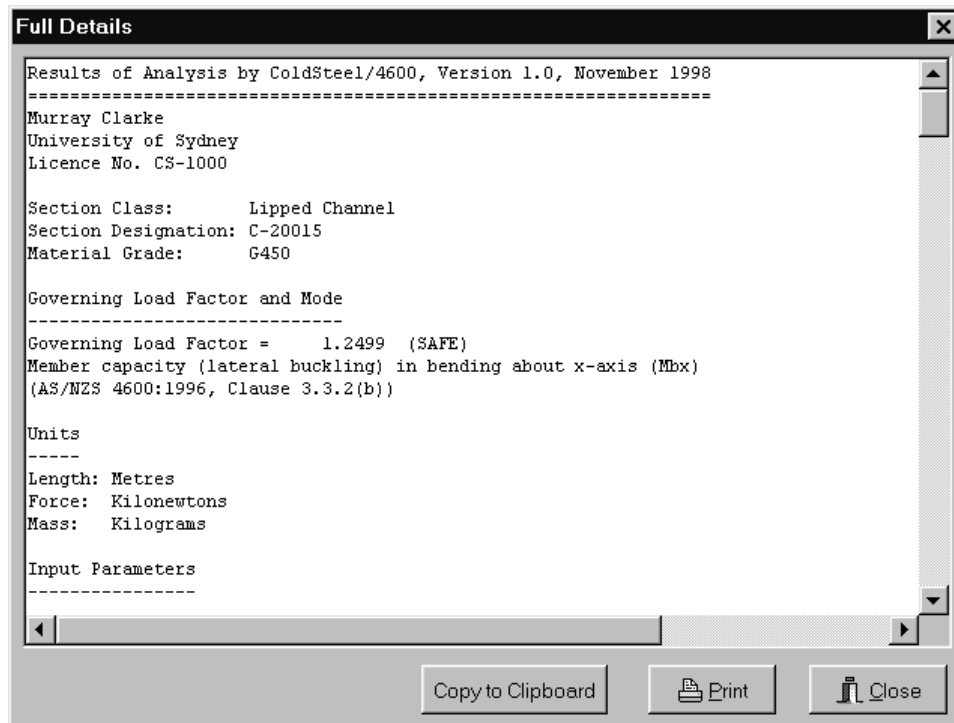

Fig. 25 Full Details form

## 4 Design Examples

The following examples are taken from the book *Design of Cold-Formed Steel Structures*, 3rd Edition, by Gregory J. Hancock, published by the Australian Institute of Steel Construction (Hancock 1998). In this book, full working and references to the relevant clauses of AS/NZS 4600:1996 are given for all the examples.

In the application of **ColdSteel** to all the ensuing examples, the following options are set:

- Thin-walled theory is used for section property calculations.
- Square corners are assumed for torsional section properties.
- Design actions are determined from first-order analysis.
- Distortional buckling in compression is ignored.

It is also assumed that the materials and cross-sections referred to in the examples are already defined in the **ColdSteel** database. If this is not the case, the **ColdSteel** database file COLDSTEEL.INI needs to be modified using a standard text editor to define the required materials and/or cross-sections. The COLDSTEEL.INI file supplied with the **ColdSteel** software contains all the required data to verify the following examples.

### Example 1 — Hat Section in Bending (Section 4.6.1 of Hancock 1998)

#### Problem

Determine the maximum design positive bending moment for bending about a horizontal axis of the hat section shown in Fig. 26. The yield stress of the material is 350 MPa. Assume the element lies along its centreline and eliminate thickness effects.

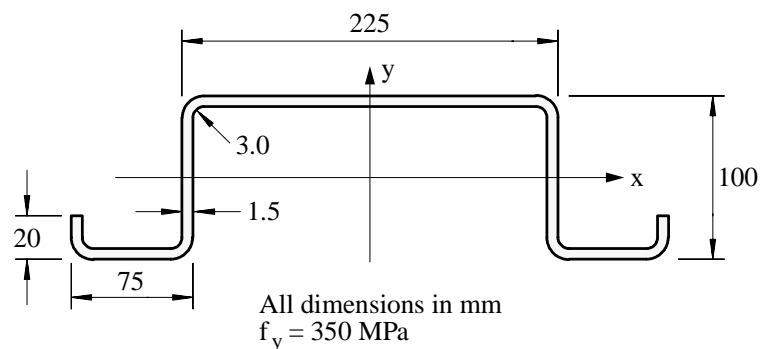

Fig. 26 Lipped hat section in bending

#### Solution

The material with a yield stress of 350 MPa is termed G350 in the **ColdSteel** database and is defined in the [Material] section. The hat section shown in Fig. 26 is termed “Ex 4.6.1” and is a specific instance of the [LippedHat] section class (see Appendix I).

In the notation of this example, a positive bending moment about the horizontal axis is one causing compression in the top flange of the hat section. In the notation and terminology of **ColdSteel**, this corresponds to a negative moment  $M_x^*$ . To determine the design moment capacity, a reference value of  $M_x^* = -1 \text{ kN}$  is input to **ColdSteel**, with all other design actions zero. To reflect the fact that a section rather than member capacity is being calculated, all member effective lengths are also input as zero. The maximum design moment capacity will then correspond to the relevant design section capacity in bending ( $\phi_b M_{sx}$ ), which will also be the computed load factor ( $\lambda$ ) when a unit design moment  $M_x^*$  is used.

The Main form of **ColdSteel** with all relevant input parameters is shown in Fig. 27. Upon clicking the Check button, the Output form is displayed as shown in Fig. 28. The maximum design bending moment is thus 5.41 kNm.

Fig. 27 Main form pertaining to Example 1

Fig. 28 Output form pertaining to Example 1

### Example 2 — Hat Section in Bending with Intermediate Stiffener in Compression Flange (Section 4.6.2 of Hancock 1998)

#### Problem

Determine the maximum design positive bending moment for bending about a horizontal axis of the hat section shown in Fig. 29 when an intermediate stiffener is added to the centre of the compression flange as shown in Fig. 29.

#### Solution

The hat section shown in Fig. 29 is termed “Ex 4.6.2” and is a specific instance of the [VeeLippedHat] section class (see Appendix I).

In the notation of this example, a positive bending moment about the horizontal axis is one causing compression in the top flange of the hat section. In the notation and terminology of **ColdSteel**, this corresponds to a negative moment  $M_x^*$ . To determine the design moment capacity, a reference value of  $M_x^* = -1\text{ kN}$  is input to **ColdSteel**, with all other design actions zero. To reflect the fact that a section

rather than member capacity is being calculated, all member effective lengths are also input as zero. The maximum design moment capacity will then correspond to the relevant design section capacity in bending ( $\phi_b M_{sx}$ ), which will also be the computed load factor ( $\lambda$ ) when a unit design moment  $M_x^*$  is used.

The Main form of **ColdSteel** with all relevant input parameters is shown in Fig. 30. Upon clicking the Check button, the Output form is displayed as shown in Fig. 31. The maximum design bending moment is thus 8.84 kNm.

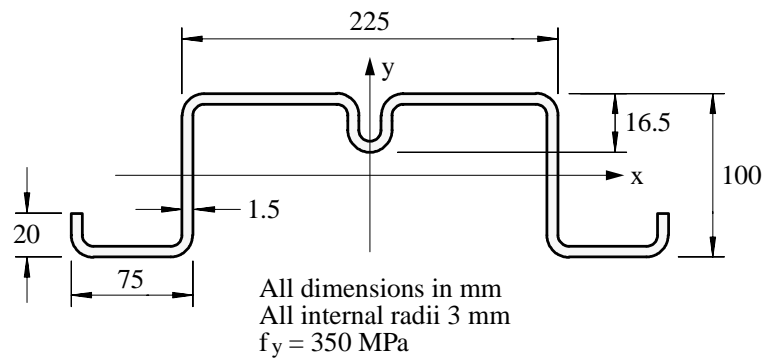

Fig. 29 Lipped hat section with intermediate V-stiffener in bending

Fig. 30 Main form pertaining to Example 2

Fig. 31 Output form pertaining to Example 2

**Example 3 — Lipped Channel Section in Bending (Section 4.6.3 of Hancock 1998)***Problem*

Determine the effective section modulus ( $Z_{ex}$ ) for bending about the horizontal axis for the “metric” C-20015 lipped channel purlin section shown in Fig. 32. The yield stress of the material is 450 MPa. Assume elements lie along their centrelines and eliminate thickness effects. The effective section modulus ( $Z_{ex}$ ) should be computed assuming the section is fully stressed ( $f^* = f_y$ ).

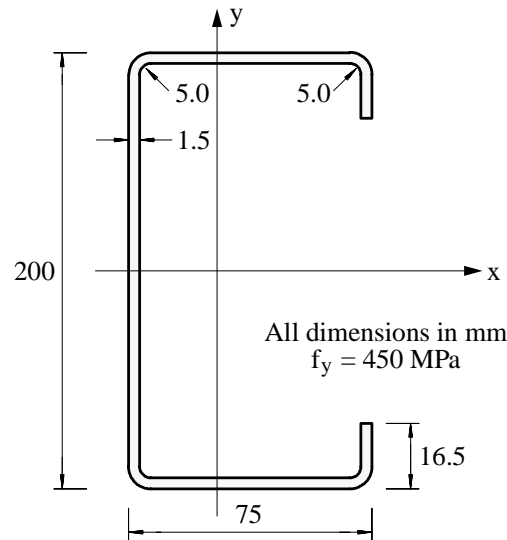

Fig. 32 “Metric” C-20015 lipped channel section purlin

*Solution*

The “metric” lipped channel section shown in Fig. 32 is termed “MC-20015” and is a specific instance of the [LippedChannel] section class defined in the **ColdSteel** database (see Appendix I). The 450 MPa yield material is defined as G450 in the **ColdSteel** database.

The effective section modulus at yield ( $Z_{ex}$ ) is computed by **ColdSteel** irrespective of the given design actions or other input parameters. The MC-20015 channel section has symmetry about the  $x$ -axis, so there is no need to distinguish between positive and negative bending.

The Main form of **ColdSteel** with all relevant input parameters is shown in Fig. 33. Upon clicking the Check button, the Output form is displayed as shown in Fig. 34. As no design actions were input, there is no governing failure mode or load factor. Clicking on the Full Details button produces a full listing of calculated quantities. The effective section properties are reproduced in Fig. 35, from which it can be seen that the effective section modulus at yield in bending is  $Z_{ex} = Z_{ex+} = Z_{ex-} = 24160 \text{ mm}^3$ .

Fig. 33 Main form pertaining to Example 3

Fig. 34 Output form pertaining to Example 3

Properties of Effective Section

```

-----
0.000255211 m2 = Ae(fy) Effective area for uniform stress fy
0.000255211 m2 = Ae(fn) Effective area for uniform stress fn
2.75207E-6 m4 = Iex+, effective 2nd moment of area (x+ bending, extreme fibre at yield)
2.75207E-6 m4 = Iex-, effective 2nd moment of area (x- bending, extreme fibre at yield)
3.9039E-7 m4 = Iey+, effective 2nd moment of area (y+ bending, extreme fibre at yield)
2.82068E-7 m4 = Iey-, effective 2nd moment of area (y- bending, extreme fibre at yield)
2.41586E-5 m3 = Zex+, effective section modulus at yield (x+ bending)
2.41586E-5 m3 = Zex-, effective section modulus at yield (x- bending)
7.20052E-6 m3 = Zey+, effective section modulus at yield (y+ bending)
6.35315E-6 m3 = Zey-, effective section modulus at yield (y- bending)

```

Fig. 35 Effective section properties for MC-20015 section of Example 3

**Example 4 — Simply Supported Lipped Channel Section Purlin (Section 5.8.1 of Hancock 1998)***Problem*

Determine the design load on the purlin section in Example 3 simply supported over a 7 m span with one brace at the centre and loaded on the tension flange as shown in Fig. 36. Use both the lateral buckling method (Clause 3.3.3.2) and the R-factor method (Clause 3.3.3.4). Distortional buckling should also be checked according to Clause 3.3.3.3.

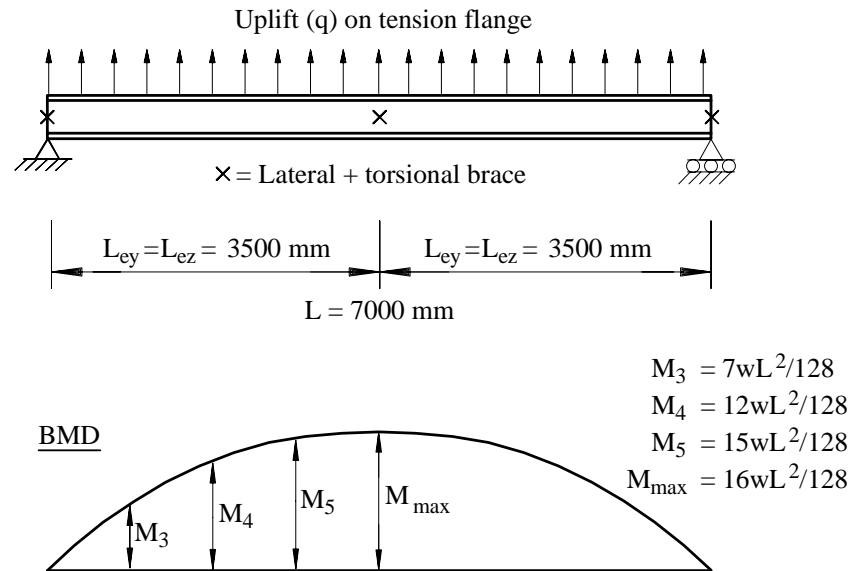

Fig. 36 Simply supported purlin with central brace

*Solution*

The relevant lipped channel section is termed “MC-20015” and is a specific instance of the [LippedChannel] section class defined in the **ColdSteel** database (see Appendix I). In **ColdSteel**, all relevant strength limit states are checked for any given set of input parameters. Thus, if distortional buckling happens to control over lateral buckling, then this is detected automatically by **ColdSteel**. The relevant **ColdSteel** input parameters to solve this problem using the lateral buckling method are (Fig. 37):

- Reference design moment:  $M_x^* = 1 \text{ kNm}$
- Effective lengths for central brace:  $L_{ey} = L_{ez} = 3.5 \text{ m}$
- $C_b$  factor for uniformly distributed load:  $C_{bx} = 1.299$

As can be seen in Fig. 38, the load factor ( $\lambda$ ) is 5.993, and the governing mode is that of lateral buckling. Distortional buckling, with a load factor of 8.503, is not critical. The maximum uniformly distributed line load is therefore deduced as

$$q_{\max}^* = \frac{8\lambda M_x^*}{L^2} = \frac{8 \times 5.993 \times 1}{7^2} = 0.978 \text{ kN/m}$$

which agrees almost identically with the result of Hancock (1998).

Fig. 37 Main form pertaining to Example 4

Fig. 38 Output form pertaining to Example 4

If the R-factor method (Clause 3.3.3.4) is used in lieu of the lateral buckling method (Clause 3.3.3.2), then the strength in bending ( $M_{bx}$ ) is determined by factoring the section capacity in bending ( $M_{sx}$ ) by the reduction factor ( $R$ ), which equals 0.85 for this configuration of outwards load and one row of bridging in simple span. Hence,

$$M_{bx} = RM_{sx} = 0.85 \times 10.871 = 9.240 \text{ kNm}$$

$$q_{\max}^* = \frac{8\phi_b M_{bx}}{L^2} = \frac{8 \times 0.9 \times 9.240}{7^2} = 1.36 \text{ kN/m}$$

which agrees identically with Hancock (1998).

### Example 5 — Distortional Buckling Stress in Bending for Lipped Channel Section (Section 5.8.2 of Hancock 1998)

#### Problem

Determine the distortional buckling stress ( $f_{odx}$ ) of the lipped channel section in Example 4 (Fig. 32) when subjected to bending about the major principal axis. Use Appendix D of AS/NZS 4600:1996.

#### Solution

The lipped channel section shown in Fig. 32 is termed “MC-20015” and is a specific instance of the [LippedChannel] section class defined in the **ColdSteel** database (see Appendix I).

The distortional buckling stress ( $f_{odx}$ ) in bending about the  $x$ -axis is computed by **ColdSteel** irrespective of the given design actions or other input parameters. The MC-20015 channel section has symmetry about the  $x$ -axis, so there is no need to distinguish between positive and negative bending.

The Main form of **ColdSteel** with all relevant input parameters is shown in Fig. 33. Upon clicking the Check button, the Output form is displayed as shown in Fig. 34. As no design actions were input, there is no governing failure mode or load factor. Clicking on the Full Details button produces a full listing of calculated quantities. The relevant output from the “Miscellaneous Properties” portion of the listing is reproduced in Fig. 39, from which it can be seen that distortional buckling stress in bending is  $f_{odx} = f_{odx+} = f_{odx-} = 245.0$  MPa. This value is slightly above the distortional buckling stress of 241.4 MPa reported by Hancock (1998) since **ColdSteel** assumes that the elastic critical buckling load in compression of the flange-lip assembly acts at the centroid of the assembly rather than at the midline fibre of the flange as assumed by Hancock (1998).

```
[      -      ] kPa = fcdc, Distortional buckling stress in pure compression
    244990 kPa = fcdx+, Distortional buckling stress in bending
    244990 kPa = fcdx-, Distortional buckling stress in bending
    290645 kPa = fcdy+, Distortional buckling stress in bending
[      -      ] kPa = fcdy-, Distortional buckling stress in bending
```

Fig. 39 Distortional buckling parameters for MC-20015 section of Example 5

### Example 6 — Lipped Z-Section in Bending (Section 5.8.4 of Hancock 1998)

#### Problem

Determine the effective section modulus ( $Z_{en}$ ) for bending about the horizontal ( $n$ ) axis for the Z-20015 lipped Z-section purlin shown in Fig. 40. The yield stress of the material is 450 MPa. Assume elements lie along their centrelines and eliminate thickness effects. The effective section modulus ( $Z_{en}$ ) should be computed assuming the section is fully stressed ( $f^* = f_y$ ).

#### Solution

The lipped Z-section shown in Fig. 40 is termed Z-20015 and is a specific instance of the [LippedZed] section class defined in the **ColdSteel** database (see Appendix I). The 450 MPa yield material is defined as G450 in the **ColdSteel** database.

The effective section modulus at yield ( $Z_{en}$ ) for bending about the horizontal ( $n$ ) (non-principal) axis is computed by **ColdSteel** irrespective of the given design actions or other input parameters. Strictly speaking, the Z-20015 section has flanges which are of slightly unequal length. When the **ColdSteel** database is initialised upon program start-up, two section classes are actually initialised from the cross-sections defined in the [LippedZed] section of the COLDSTEEL.INI file. These section classes are:

- Lipped Z-Section, where the specified flange dimensions (which may be unequal) are modelled; and
- Lipped Z-Section (Equal Flanges), where the two given flange dimensions are averaged, this giving the section perfect point-symmetry.

For the purposes of this example, the Lipped Z-Section (Equal Flanges) section class will be used to avoid the inconvenience of having to distinguish the sense of bending as in the unequal-flange model.

The Main form of **ColdSteel** with all relevant input parameters is shown in Fig. 41. Upon clicking the Check button and display of the Output form, clicking on the Full Details button produces a full listing of calculated quantities. The effective section properties are reproduced in Fig. 42, from which it can be seen that the effective section modulus at yield in bending is  $Z_{en} = Z_{en+} = Z_{en-} = 23850$  mm<sup>3</sup>.

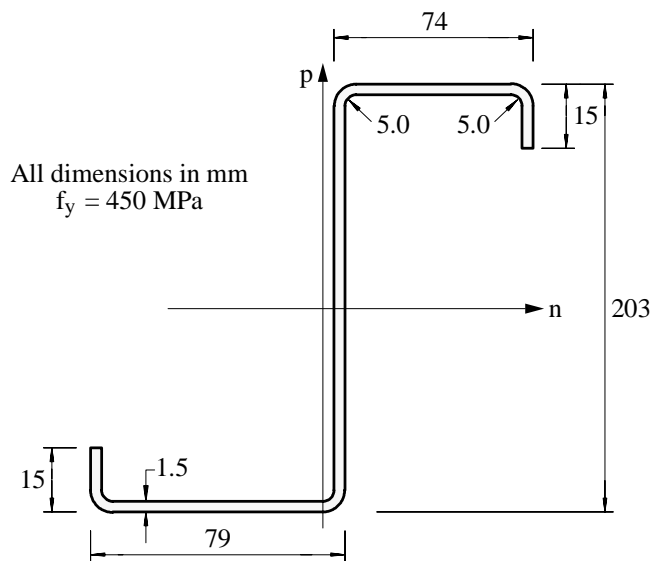

Fig. 40 Z-20015 lipped Z-section purlin

Fig. 41 Main form pertaining to Example 6

## Properties of Effective Section

0.000248469	m <sup>2</sup>	= Ae( $f_y$ ) Effective area for uniform stress $f_y$
0.000248469	m <sup>2</sup>	= Ae( $f_n$ ) Effective area for uniform stress $f_n$
2.79356E-6	m <sup>4</sup>	= Ien+, effective 2nd moment of area (n+ bending, extreme fibre at yield)
2.79356E-6	m <sup>4</sup>	= Ien-, effective 2nd moment of area (n- bending, extreme fibre at yield)
4.15367E-7	m <sup>4</sup>	= Iep+, effective 2nd moment of area (p+ bending, extreme fibre at yield)
4.15367E-7	m <sup>4</sup>	= Iep-, effective 2nd moment of area (p- bending, extreme fibre at yield)
2.38529E-5	m <sup>3</sup>	= Zen+, effective section modulus at yield (n+ bending)
2.38529E-5	m <sup>3</sup>	= Zen-, effective section modulus at yield (n- bending)
5.03922E-6	m <sup>3</sup>	= Zep+, effective section modulus at yield (p+ bending)
5.03922E-6	m <sup>3</sup>	= Zep-, effective section modulus at yield (p- bending)

Fig. 42 Effective section properties for Z-20015 (equal flanges) section of Example 6

**Example 7 — Continuous Lapped Z-Section Purlin (Section 5.8.3 of Hancock 1998)***Problem*

Determine the upwards and downwards design load capacity ( $q_{max}^*$  kN/m) of the Z-section purlin (Z-20015) system shown in Fig. 43. The purlin is continuous over three 7 m spans with interior lap lengths of 900 mm, and has sheeting screw-fastened to the top flange. Each span has one brace, and in the exterior spans this brace is positioned 2800 mm from the outer support as shown in Fig. 43.

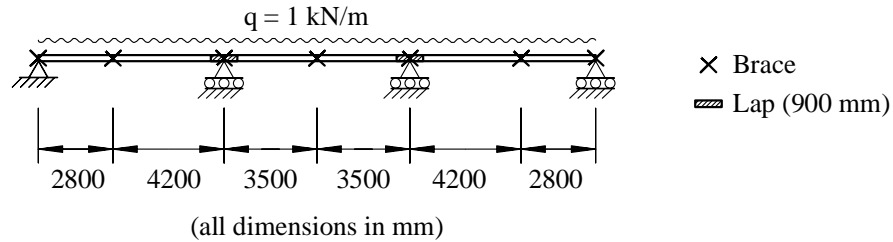

Fig. 43 Three-span lapped purlin system

*Solution*

The first step in solving the problem is to perform the structural analysis using a suitable program. Lapped regions may be modelled using elements with double the flexural stiffness of those employed in unlapped regions. Based on this assumption and the application of a uniformly distributed load of  $q = 1.0$  kN/m, the bending moment and shear force diagrams for the three-span purlin system are shown in Fig. 44.

In the **ColdSteel** member strength checks which follow, it is assumed that the flanges of the Z-20015 section are averaged and equal in length.

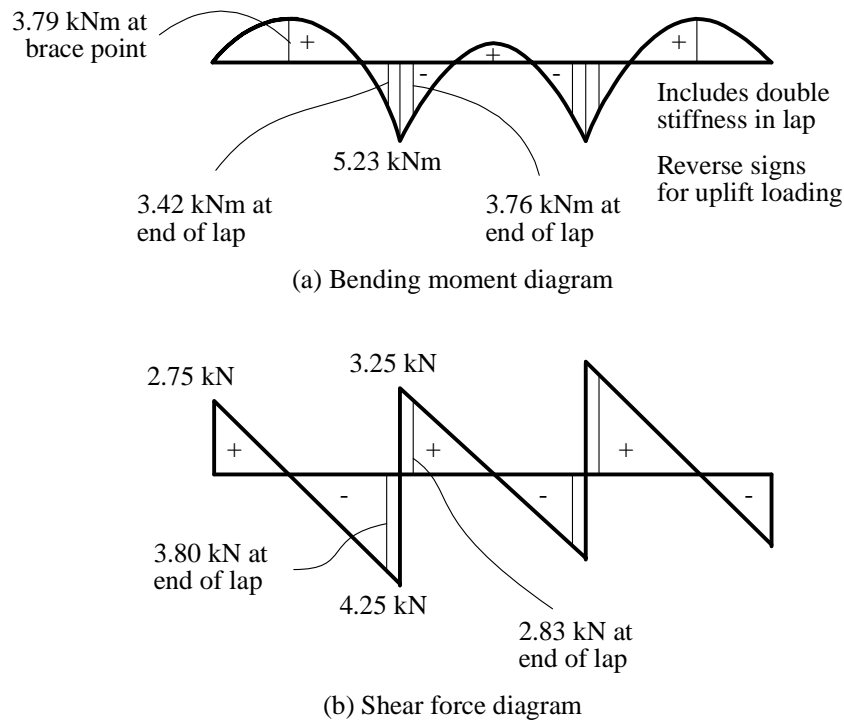

Fig. 44 Bending moment and shear force diagrams for three-span lapped purlin system

## Capacity under uplift load

### End segment in end span

Based on a unit uniformly distributed uplift load ( $q$ ), the design moment about the horizontal  $n$ -axis is  $M_n^* = 3.79$  kNm. The minor-axis and torsional effective lengths are assumed to be equal to the segment length, hence  $L_{ey} = L_{ez} = 2800$  mm. The equivalent moment coefficient  $C_b$  can be determined using the formula

$$C_b = \frac{12.5M_{\max}}{2.5M_{\max} + 3M_{0.25} + 4M_{0.50} + 3M_{0.75}} \quad (9)$$

in which

- $M_{\max}$  = absolute value of the maximum moment in the unbraced segment
- $M_{0.25}$  = absolute value of the moment at the quarter point of the unbraced segment
- $M_{0.50}$  = absolute value of the moment at the centreline of the unbraced segment
- $M_{0.75}$  = absolute value of the moment at the three-quarter point of the unbraced segment.

As shown in Hancock (1998), the  $C_b$  factor for the end segment evaluates to  $C_{bx} = 1.29$ . The elastic buckling moment is calculated in accordance with Clause 3.3.3.2(a) of AS/NZS 4600:1996.

The **ColdSteel** Main form complete with all the relevant input parameters is shown in Fig. 45 and the Output form obtained upon clicking the Check button is shown in Fig. 46. Assuming the end span of the end segment is governing, the maximum uniformly distributed load which can be applied to the purlin system is thus 2.05 kN/m. This value is slightly greater than the corresponding value of 1.92 kN/m reported by Hancock (1998) for the following reasons:

- In **ColdSteel**, both flanges have been averaged in length whereas in Hancock (1998) it was assumed that the wide flange is in compression.
- In **ColdSteel**, the elastic lateral buckling moment ( $M_{ox}$ ) is evaluated using Eq. 2 whereas in Hancock (1998), the simplified and approximate formula from AS/NZS 4600:1996

$$M_{ox} = \frac{\pi^2 EdI_{yc}}{2L^2} \quad (10)$$

for point-symmetric Z-sections was used. In Eq. 10 above,  $d$  is the depth of the section measured between the centrelines of the flanges,  $L$  is the unbraced length of the member, and  $I_{yc}$  is the second moment of area of the compression portion of the full section about the centroidal axis of the full-section parallel to the web.

### Interior segment in end span

Following the approach of Hancock (1998), the minor-axis ( $L_{ey}$ ) and torsional ( $L_{ez}$ ) effective lengths are assumed to be equal to the distance between the central brace and the point of contraflexure in the end span. The point of contraflexure has been used to define the end of the segment since sheeting is attached to the top flange by screw-fastening and it is therefore assumed to provide lateral restraint to the top compression flange between the point of contraflexure and the first interior support.

As shown in Hancock (1998), the  $C_b$  factor for the interior segment evaluates to  $C_{bx} = 1.31$ . The elastic buckling moment is calculated in accordance with Clause 3.3.3.2(a) of AS/NZS 4600:1996. The effective lengths are given by  $L_{ey} = L_{ez} = 2700$  mm. The design moment is  $M_n^* = 3.79$  kNm.

The **ColdSteel** Main form complete with all the relevant input parameters is shown in Fig. 47 and the Output form obtained upon clicking the Check button is shown in Fig. 48. Assuming the interior segment of the end span is governing, the maximum uniformly distributed load which can be applied to the purlin system is thus 2.11 kN/m. For the same reasons as outlined previously, this value is slightly greater than the corresponding value of 2.02 kN/m reported by Hancock (1998).

Fig. 45 Main form for check of end segment in end span under uplift load

Fig. 46 Output form for check of end segment in end span under uplift load

Fig. 47 Main form for check of interior segment in end span under uplift load

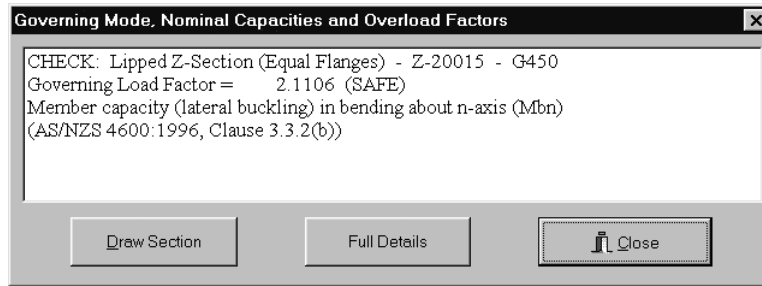

Fig. 48 Output form for check of interior segment in end span under uplift load

#### System capacity based on rational elastic buckling analysis

A rational elastic lateral buckling analysis of the whole purlin system under uplift load has been performed by Hancock (1998). From this analysis it can be deduced that the elastic critical buckling moment ( $M_{cr}$ ) is 13.34 kNm. This result can be used to determine the maximum design load as described hereafter. The Options/Bending form of **ColdSteel** needs to be set to indicate that the critical moment ( $M_{cr}$ ) will be computed according to Clause 3.3.3.2(b) of AS/NZS 4600:1996, the elastic buckling moment ( $M_{cr}$ ) will be determined using a rational elastic buckling analysis, and the value of  $M_{cr}$  is 13.34 kNm. The completed Options/Bending form is shown in Fig. 49. The corresponding Main and Output forms are shown in Figs. 50 and 51, respectively, from which it can be deduced that the maximum upwards design load is 2.00 kN/m, which is very close to Hancock's (1998) result of 1.98 kN/m.

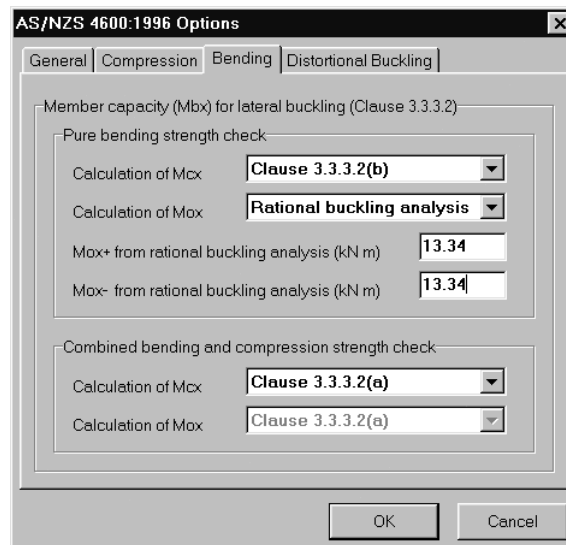

Fig. 49 Options/Bending form for check of purlin system under uplift load using rational elastic buckling analysis

Fig. 50 Main form for check of purlin system under uplift load using rational elastic buckling analysis

Fig. 51 Output form for check of purlin system under uplift load using rational elastic buckling analysis

#### Other design checks

In all of the **ColdSteel** calculations carried out for this example, distortional buckling has been checked and found not to govern over lateral buckling. Inspection of the bending moment diagram shown in Fig. 44 also indicates that distortional buckling will not be critical in the lapped region over the support because the moment there (5.23 kNm) is less than half the maximum moment in the unlapped region (3.79 kNm).

Combined bending and shear should also be checked at critical locations in the beam such as at the end of the lap. For brevity, the details of these design checks are not included as part of this example.

#### Capacity under downwards load

##### End segment in end span

Under downwards load, the end segment of the end span is in positive bending exclusively so that the top flange is restrained continuously by the sheeting. Lateral buckling of this segment is therefore assumed not to occur.

##### Interior segment in end span

The Center for Cold-Formed Steel Structures from the University of Missouri–Rolla, USA, have suggested (CCFSS 1992) that the unbraced length ( $L_{ey} = L_{ez}$ ) should be taken as the distance from the inflection point to the end of the lap with  $C_{bx} = 1.75$ . In this case,  $L_{ex} = L_{ey} = 1050$  mm. Based on a unit uniformly distributed load, the maximum design moment ( $M_x^*$ ) in the physical segment remains 3.79 kNm. The Main form with relevant input parameters is shown in Fig. 52. The result of the strength check is shown in Fig. 53 from which it can be seen that distortional buckling governs and the maximum design load is 2.19 kN/m.

Inspection of the Full Details output reveals that the maximum design load based on lateral buckling failure is 2.55 kN/m.

Fig. 52 Main form for check of interior segment in end span under downwards load

Fig. 53 Output form for check of interior segment in end span under downwards load

### Summary

From the results determined in this example, the maximum load capacities of the three-span lapped purlin system shown in Fig. 43 are:

*Upwards load:*  $q_{\max}^* = 2.05 \text{ kN/m}$  ( $C_b$ -factor approach, Clause 3.3.3.2(a))

$q_{\max}^* = 2.00 \text{ kN/m}$  (Rational buckling analysis approach, Clause 3.3.3.2(b))

*Downwards load:*  $q_{\max}^* = 2.19 \text{ kN/m}$

**Example 8 — Lipped Z-Section in Combined Bending and Shear (Section 6.8.1 of Hancock 1998)***Problem*

In a lapped Z-20015 purlin system, the maximum design moment ( $M_n^*$ ) and shear ( $V_p^*$ ) at the end of the lap computed using the R-factor approach are  $M_n^* = 7.44$  kNm and  $V_p^* = 8.26$  kN. Check the limit state of combined bending and shear at the end of the lap.

*Solution*

The Z-20015 section is shown in Fig. 40 and is a specific instance of the [LippedZed] section class defined in the **ColdSteel** database (see Appendix I). The 450 MPa yield material is defined as G450 in the **ColdSteel** database. In this example, the “equal-flange” variant of the lipped Z-section is used (see Example 6).

Since the combined bending and shear check is essentially a section capacity check, all the effective lengths can be input as zero. The Main form of **ColdSteel** with all relevant input parameters is shown in Fig. 54. Upon clicking the Check button, the Output form is displayed as shown in Fig. 55. The load factor of 1.11 indicates that combined bending and shear at the end of the lap is satisfactory and does not control the design of the purlin system.

Fig. 54 Main form pertaining to Example 8

Fig. 55 Output form pertaining to Example 8

**Example 9 — Combined Bearing and Bending of Hat Section (Section 6.8.2 of Hancock 1998)***Problem*

Determine the design bearing capacity of the hat section in Example 1 for a bearing length of  $l_b = 50$  mm at an interior loading point. Determine also the design bending capacity (about the  $x$ -axis with the top flange in compression) at the loading point when the load is half of the bearing capacity computed.

*Solution*

In the terminology of AS/NZS 4600:1996 for bearing capacity, a single interior loading point is defined by  $c > 1.5d_1$  and  $e > 1.5d_1$ . Hence we may assume  $c = e = 2d_1 = 150$  mm for **ColdSteel** calculations.

An initial **ColdSteel** analysis using the above parameters indicates that the design bearing capacity of the “Ex 4.6.1” [LippedHat] section is  $\phi R_{by} = 18.046$  kN. Hence, in the combined bending and bearing analysis, the bearing load ( $R_y^*$ ) should be input as 9.023 kN, and the bending moment about the  $x$ -axis ( $M_x^*$ , negative) varied until a load factor of 1.0 is achieved. It can quickly be established that when  $R_y^* = 9.023$  kN, the maximum design moment is  $M_x^* = -4.784$  kNm. Comparing this result to the design section capacity in bending of 5.41 kNm (Example 1), it can be seen that a bearing load equal to half the design bearing capacity reduces the bending capacity by 11.6 per cent.

The Main and Output forms of **ColdSteel** pertaining to the above calculations are shown in Figs. 56 and 57, respectively.

Fig. 56 Main form pertaining to Example 9

Fig. 57 Output form pertaining to Example 9

**Example 10 — Square Hollow Section Column (Section 7.6.1 of Hancock 1998)***Problem*

Determine the maximum design compressive axial force for the 76×76×2.0 SHS cold-formed square hollow section shown in Fig. 58. Assume that the effective lengths  $L_{ex}$ ,  $L_{ey}$  and  $L_{ez}$  are all equal to 3.0 m. The nominal yield strength of the material is 350 MPa.

*Solution*

The 76×76×2.0 SHS section is a specific instance of the [SHS] section class defined in the **ColdSteel** database (see Appendix I). The 350 MPa yield material is defined as C350 in the **ColdSteel** database.

In this example, the maximum design axial compressive force ( $N^*$ ) corresponds to the design compression capacity ( $\phi_c N_c$ ), which is equal to the computed load factor when a reference load of  $N^* = 1$  kN is input to **ColdSteel**.

The Main and Output forms of **ColdSteel** pertaining to this example are shown in Figs. 59 and 60, respectively, from which it can be seen that the maximum design compression force is  $N_{max}^* = 82.0$  kN.

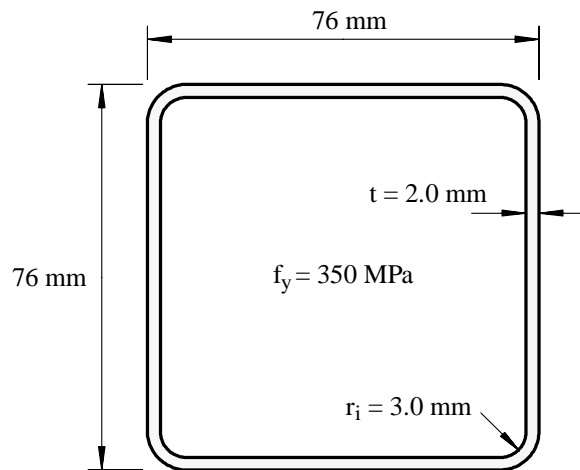

Fig. 58 Square hollow section for Example 10

Section		Axis System	
SHS Section	76 x 76 x 2.0 SHS	<input checked="" type="radio"/> Principal (x-y)	<input type="radio"/> Non-principal (n-p)
Material: C350 <input checked="" type="checkbox"/> Use default material			
Design Actions (1st-Order)		Lengths	
$N^*$ (kN)	-1	L (m)	3
$M_x^*$ (kN m)	0	$L_{ex}$ (m)	3
$M_y^*$ (kN m)	0	$L_{ey}$ (m)	3
$V_x^*$ (kN)	0	$L_{ez}$ (m)	3
$V_y^*$ (kN)	0	Tension Factors	
$R_y^*$ (kN)	0	kt	1
		br (m)	0
		Cb/Cm Factors (Mo)	
		Clause 3.3.3.2(a)	
		Cbx	1
		Cby	1
		Clause 3.3.3.2(b)	
		Cmx	1
		Cm Factors (N+M)	
		Clause 3.5.1	
		Cmx	1
		Cmy	1
		Bearing	
		Lb(y) (m)	0.1
		c(y) (m)	0.1
		e(y) (m)	0.1

Memory Used: 272072

Fig. 59 Main form pertaining to Example 10

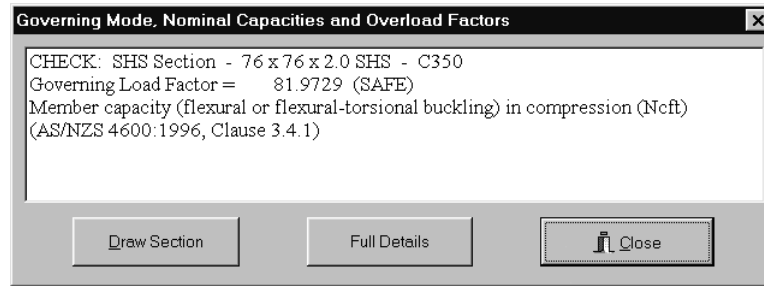

Fig. 60 Output form pertaining to Example 10

**Example 11 — Unlipped Channel Column (Section 7.6.2 of Hancock 1998)***Problem*

Determine the maximum design compressive axial force for the unlipped channel section shown in Fig. 61 assuming the channel is loaded concentrically through the centroid of the effective section and the effective lengths in flexure ( $L_{ex}$ ,  $L_{ey}$ ) and torsion ( $L_{ct}$ ) are 1500 mm. The nominal yield stress ( $f_y$ ) is 240 MPa.

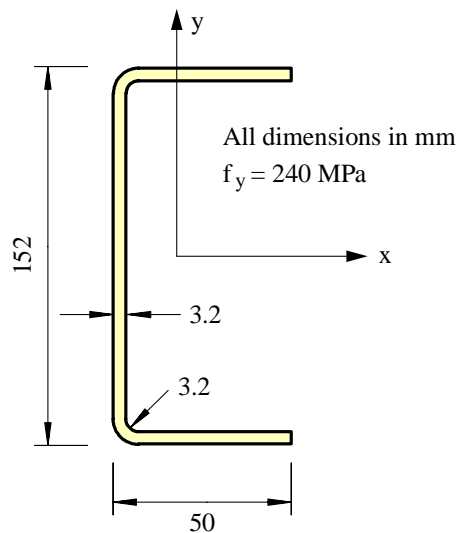

Fig. 61 Unlipped channel section for Example 11

*Solution*

The unlipped channel section depicted in Fig. 61 and termed “Ex 7.6.2” is a specific instance of the [PlainChannel] section class defined in the **ColdSteel** database (see Appendix I). The 240 MPa yield material is defined as C240 in the **ColdSteel** database.

In this example, the channel is loaded through the centroid of the effective section and hence the maximum design axial compressive force ( $N^*$ ) corresponds to the design compression capacity ( $\phi_c N_c$ ), which is equal to the computed load factor when a reference load of  $N^* = 1$  kN is input to **ColdSteel**. The fact that the channel is loaded through the effective centroid rather than the full centroid is indicated by setting the appropriate option in the Options/Compression form as shown in Fig. 62.

The Main and Output forms of **ColdSteel** pertaining to this example are shown in Figs. 63 and 64, respectively, from which it can be seen that the maximum design compression force is  $N_{\max}^* = 93.4$  kN. It is interesting to note that if the member is assumed to be loaded through the full-section centroid rather than the effective-section centroid then the maximum capacity remains at  $N_{\max}^* = 93.4$  kN. This is because the section is fully effective under a uniform compressive stress of  $f_n$  and hence the full and effective centroids coincide.

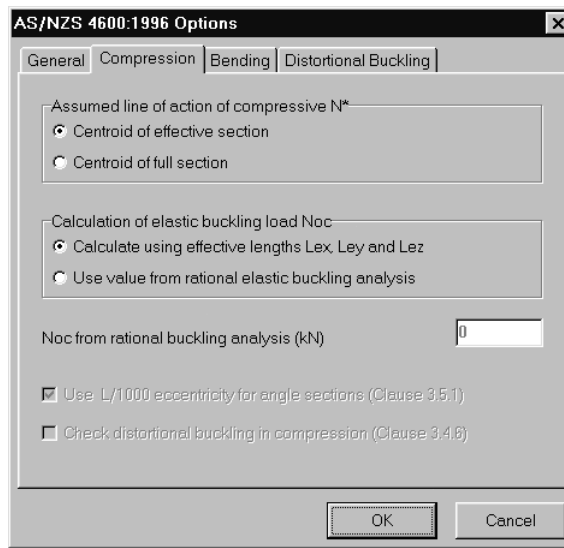

Fig. 62 Options/Compression form indicating loading through the effective centroid

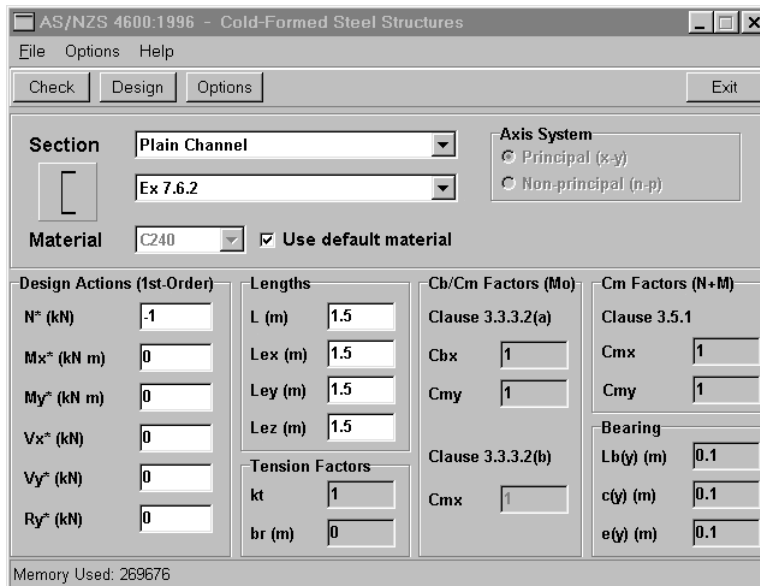

Fig. 63 Main form pertaining to Example 11

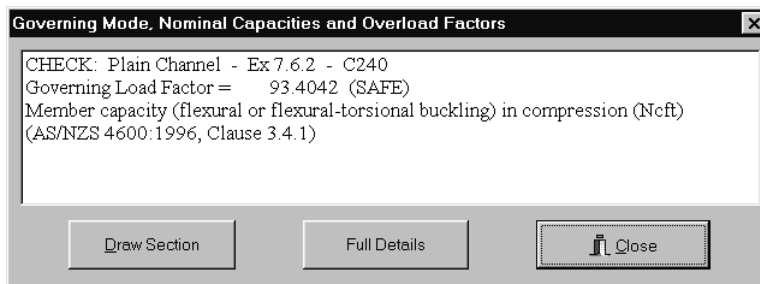

Fig. 64 Output form pertaining to Example 11

**Example 12 —Lipped Channel Column (Section 7.6.3 of Hancock 1998)***Problem*

Determine the maximum design compressive axial force for the lipped channel section shown in Fig. 65 assuming the channel is loaded concentrically through the centroid of the effective section and the effective lengths in flexure ( $L_{ex}$ ,  $L_{ey}$ ) and torsion ( $L_{et}$ ) are based on a lateral and torsional restraint in the plane of symmetry at mid-height ( $L_{ex} = 2000$  mm,  $L_{ey} = L_{et} = 1000$  mm). The nominal yield stress ( $f_y$ ) is 300 MPa.

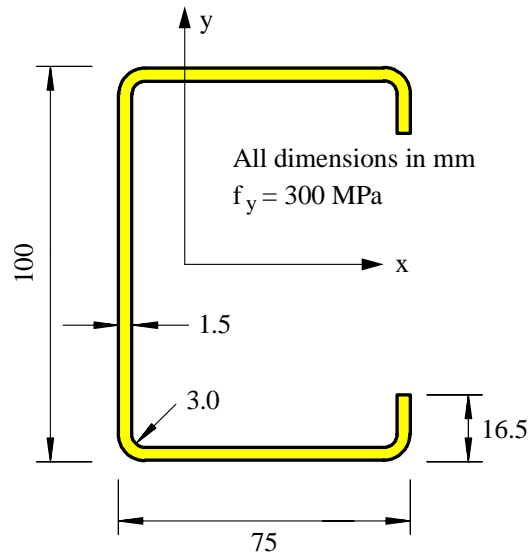

Fig. 65 Lipped channel section for Example 12

*Solution*

The lipped channel section depicted in Fig. 65 and termed “Ex 7.6.3” is a specific instance of the [LippedChannel] section class defined in the **ColdSteel** database (see Appendix I). The 300 MPa yield material is defined as C300 in the **ColdSteel** database.

In this example, the lipped channel is loaded through the centroid of the effective section and hence the maximum design axial compressive force ( $N^*$ ) corresponds to the design compression capacity ( $\phi_c N_c$ ), which is equal to the computed load factor when a reference load of  $N^* = 1$  kN is input to **ColdSteel**. The fact that the channel is loaded through the effective centroid rather than the full centroid is indicated by setting the appropriate option in the Options/Compression form as shown in Fig. 62.

The Main and Output forms of **ColdSteel** pertaining to this example are shown in Figs. 66 and 67, respectively, from which it can be seen that the maximum design compression force is  $N_{\max}^* = 57.6$  kN. It is interesting to note that if the member is assumed to be loaded through the full-section centroid rather than the effective-section centroid then the maximum capacity reduces to  $N_{\max}^* = 50.2$  kN due to the eccentricity of the full and effective section centroids and the consequent additional bending moment ( $M_y^*$ ) that is introduced.

Fig. 66 Main form pertaining to Example 12

Fig. 67 Output form pertaining to Example 12

### Example 13 — Unlipped Channel Beam-Column Bent in Plane of Symmetry (Section 8.5.1 of Hancock 1998)

#### Problem

Calculate the maximum design axial compressive load in the unlipped channel shown in Fig. 61 assuming the channel is loaded with an axial force on the line of the  $x$ -axis at a point in line with the flange tips. As in the previous example, the effective lengths in flexure ( $L_{ex}$ ,  $L_{ey}$ ) and torsion ( $L_{ez}$ ) are 1500 mm, and the nominal yield stress ( $f_y$ ) is 240 MPa.

#### Solution

The relevant unlipped channel section “Ex 7.6.2” is the same as that used in Example 11. It can be seen from the Full Details output given in Fig. 68 that the dimension from the full-section centroid to the extreme fibre in the positive  $x$ -axis direction is 0.03869 m. Thus, in this example a compressive load of  $N^* = 1.0$  kN co-exists with a bending moment about the minor  $y$ -axis of  $M_y^* = +0.03869$  kNm. The beam is in uniform bending and therefore the moment modification coefficients  $C_{my}$  used in lateral buckling calculations and in the beam-column strength interaction formula are both unity. The Main form pertaining to this example is shown in Fig. 69 and the Output form obtained upon clicking the Check button is shown in Fig. 70. The maximum compressive load which can be applied eccentrically at the flange tips of the unlipped channel section is therefore  $N_{max}^* = 17.5$  kN.

## Properties of Full Section

0.24148	m	= Wf, Feed width
0.000772735	m <sup>2</sup>	= A (full section)
0.000772735	m <sup>2</sup>	= A (net section)
0.0097073	m	= xc, x-ordinate of centroid (full section)
0	m	= yc, y-ordinate of centroid (full section)
-0.0255392	m	= xo, x-ordinate of shear centre (referred to principal axes)
0	m	= yo, y-ordinate of shear centre (referred to principal axes)
2.51948E-6	m <sup>4</sup>	= Ix (full section)
1.69059E-7	m <sup>4</sup>	= Iy (full section)
0	m <sup>4</sup>	= Ixy (full section)
0	deg	= Inclination of principal axes (full section)
0.0571005	m	= rx (full section), radius of gyration
0.0147912	m	= ry (full section), radius of gyration
-0.0113073	m	= Extreme negative x-ordinate (full section)
0.0386927	m	= Extreme positive x-ordinate (full section)
-0.076	m	= Extreme negative y-ordinate (full section)
0.076	m	= Extreme positive y-ordinate (full section)
3.3151E-5	m <sup>3</sup>	= Zx+, Full section modulus (yield at extreme positive x-ordinate)
3.3151E-5	m <sup>3</sup>	= Zx-, Full section modulus (yield at extreme negative x-ordinate)
4.36927E-6	m <sup>3</sup>	= Zy+, Full section modulus (yield at extreme positive y-ordinate)
1.49513E-5	m <sup>3</sup>	= Zy-, Full section modulus (yield at extreme negative y-ordinate)
2.6376E-9	m <sup>4</sup>	= J, torsion constant (full section)
0.0645648	m	= r01 (full section)
0	m	= betax, monosymmetry parameter (referred to principal axes)
0.168364	m	= betay, monosymmetry parameter (referred to principal axes)
6.74926E-10	m <sup>6</sup>	= Iw, warping constant (full section)
6.06597	kg/m	= Mass per unit length
0.489359	m	= Profile distance
0.0806729	m <sup>2</sup> /kg	= Profile surface area (Area/Mass)

Fig. 68 Full-section properties for [PlainChannel] section "Ex 7.6.2" used in Examples 11, 13, and 14

Fig. 69 Main form pertaining to Example 13

Fig. 70 Output form pertaining to Example 13

### Example 14 — Unlipped Channel Beam-Column Bent about Plane of Symmetry (Section 8.5.2 of Hancock 1998)

#### Problem

Calculate the maximum design axial compressive load in the unlipped channel shown in Fig. 61 assuming the channel is loaded with an axial force on the intersection of the  $y$ -axis with one flange. As in the previous example, the effective lengths in flexure ( $L_{ex}$ ,  $L_{ey}$ ) and torsion ( $L_{ez}$ ) are 1500 mm, and the nominal yield stress ( $f_y$ ) is 240 MPa.

#### Solution

The relevant unlipped channel section “Ex 7.6.2” is the same as that used in the previous example. It can be seen from the Full Details output given in Fig. 68 that the dimension from the full-section centroid to the extreme fibre in the positive or negative  $y$ -axis direction is 0.076 m. Thus, in this example a compressive load of  $N^* = 1.0$  kN co-exists with a bending moment about the major  $x$ -axis of  $M_x^* = \pm 0.076$  kNm. The beam is in uniform bending and therefore the moment modification coefficient  $C_{bx}$  used in lateral buckling calculations and  $C_{mx}$  used in the beam-column strength interaction formula are both unity. The Main form pertaining to this example is shown in Fig. 71 and the Output form obtained upon clicking the Check button is shown in Fig. 72. The maximum compressive load which can be applied eccentrically at the intersection of the  $y$ -axis with the extreme fibre of one flange is therefore  $N_{max}^* = 43.3$  kN.

Fig. 71 Main form pertaining to Example 14

Fig. 72 Output form pertaining to Example 14

### Example 15 — Lipped Channel Beam-Column Bent in Plane of Symmetry (Section 8.5.3 of Hancock 1998)

#### Problem

Calculate the maximum design axial compressive load in the lipped channel shown in Fig. 65 assuming the channel is loaded with an axial force at the intersection of the  $x$ -axis with the outer edge of the web. As in Example 12, the effective lengths are  $L_{ex}=2000$  mm,  $L_{ey}=1000$  mm and  $L_{ec}=1000$  mm, and the nominal yield stress ( $f_y$ ) is 300 MPa.

#### Solution

The relevant lipped channel section “Ex 7.6.3” is the same as that used in Example 12. It can be seen from the Full Details output given in Fig. 73 that the dimension from the full-section centroid to the extreme fibre in the negative  $x$ -axis direction is 0.028400 m. Furthermore, Fig. 74 indicates that under a uniform stress ( $f_n$ ), the effective section centroid is  $-0.003394$  m closer to the web than the full-section centroid, measured along the axis of symmetry. Thus, in this example a compressive load of  $N^f = 1.0$  kN co-exists with a bending moment about the minor  $y$ -axis of  $M_y^* = (-0.028400 + 0.003394) = -0.025006$  kNm. The beam is in uniform bending and therefore the moment modification coefficients  $C_{my}$  used in lateral buckling calculations and in the beam-column strength interaction formula are both unity. The Main form pertaining to this example is shown in Fig. 75 and the Output form obtained upon clicking the Check button is shown in Fig. 76. The maximum compressive load which can be applied eccentrically at the intersection of the axis of symmetry and the outer edge of the web of the lipped channel section is therefore  $N_{max}^* = 31.7$  kN.

#### Properties of Full Section

0.270562 m	= Wf, Feed width
0.000405843 m <sup>2</sup>	= A (full section)
0.000405843 m <sup>2</sup>	= A (net section)
0.0276495 m	= xc, x-ordinate of centroid (full section)
0 m	= yc, y-ordinate of centroid (full section)
-0.0656134 m	= xo, x-ordinate of shear centre (referred to principal axes)
0 m	= yo, y-ordinate of shear centre (referred to principal axes)
7.12262E-7 m <sup>4</sup>	= Ix (full section)
3.1562E-7 m <sup>4</sup>	= Iy (full section)
0 m <sup>4</sup>	= Ixy (full section)
0 deg	= Inclination of principal axes (full section)
0.0418929 m	= rx (full section), radius of gyration
0.0278871 m	= ry (full section), radius of gyration
-0.0283995 m	= Extreme negative x-ordinate (full section)
0.0466005 m	= Extreme positive x-ordinate (full section)
-0.05 m	= Extreme negative y-ordinate (full section)
0.05 m	= Extreme positive y-ordinate (full section)
1.42452E-5 m <sup>3</sup>	= Zx+, Full section modulus (yield at extreme positive y-ordinate)
1.42452E-5 m <sup>3</sup>	= Zx-, Full section modulus (yield at extreme negative y-ordinate)
6.77288E-6 m <sup>3</sup>	= Zy+, Full section modulus (yield at extreme positive x-ordinate)
1.11136E-5 m <sup>3</sup>	= Zy-, Full section modulus (yield at extreme negative x-ordinate)
3.04382E-10 m <sup>4</sup>	= J, torsion constant (full section)
0.082889 m	= rol (full section)
0 m	= betax, monosymmetry parameter (referred to principal axes)
0.159306 m	= betay, monosymmetry parameter (referred to principal axes)
7.52148E-10 m <sup>6</sup>	= Iw, warping constant (full section)
3.18587 kg/m	= Mass per unit length
0.544124 m	= Profile distance
0.170793 m <sup>2</sup> /kg	= Profile surface area (Area/Mass)

Fig. 73 Full-section properties for [LippedChannel] section “Ex 7.6.3” used in Examples 12 and 15

-0.00478201 m	= x-ordinate of C(full)->C(effective) (fy)
0 m	= y-ordinate of C(full)->C(effective) (fy)
-0.0033939 m	= x-ordinate of C(full)->C(effective) (fn)
0 m	= y-ordinate of C(full)->C(effective) (fn)

Fig. 74 Shift of effective centroid from full section centroid for the two cases of uniform compressive stresses  $f_y$  and  $f_n$  for the [LippedChannel] section “Ex 7.6.3” used in Examples 12 and 15

Fig. 75 Main form pertaining to Example 15

Fig. 76 Output form pertaining to Example 15

## Appendix I. The ColdSteel Database

When **ColdSteel** is executed, a database of available materials and profiles is initialised. These components are specified in the initialisation file COLDSTEEL.INI. This file must reside in the same directory as the executable program **ColdSteel.exe**, and can be edited freely using an ordinary text editor. An example COLDSTEEL.INI file is given at the end of this appendix.

The various materials comprising the profiles are specified using the [Material] keyword, followed by one line of data for each material defined. The various profiles are defined in the database using a keyword specific to that profile. For example, standard lipped channel sections are defined using the [LippedChannel] keyword, and standard lipped Z-section profiles are defined using the [LippedZed] keyword. The materials must be defined first in the COLDSTEEL.INI file. The various profiles may then be defined subsequently in any convenient order. In addition to defining key dimensions, profile definitions may include other cross-section specific data such as distortional buckling stresses calculated using a rational elastic buckling analysis of the plate assemblage. The profile dimensions are compulsory data, but distortional buckling stresses are optional data.

The data format for each component is described in the following sections. The data type of each item is described by the following format characters:

- S String variable
- I Integer variable
- F Floating point (real) variable.

In addition, an open square bracket [ indicates the commencement of an optional block of data, and a closing square bracket ] signifies the end of the optional data. It is not possible to include part of the data between the open and closing brackets—it must all be provided or none at all.

To facilitate the use of correct and consistent units in the purlin system database, the dimension of each quantity listed in the following tables is given in terms of the fundamental dimensions of length (L), force (F), mass (M) and angle (A). Although the same symbol (F) is used to indicate both a floating point (real) variable and the basic dimension of force (F), the correct interpretation should always be clear from the context.

### [Material]: Specify a list of materials

Each material must be defined on a separate line using the following format.

Format	Description	Dimension
S	Material name, enclosed in quotation marks (e.g. "G450")	
I	Unit combination code; 0 = (millimetres, newtons, kilograms)	
F	Young's modulus ( $E$ )	$F.L^{-2}$
F	Shear modulus ( $G$ )	$F.L^{-2}$
F	Yield stress ( $f_y$ )	$F.L^{-2}$
F	Ultimate tensile strength ( $f_u$ )	$F.L^{-2}$
F	Density ( $\rho$ )	$M.L^{-3}$

**[PlainEqualAngle]: Specify a list of plain (unlipped) equal-angle sections**

The profile geometry of a plain equal-angle section is shown in Fig. I.1. Each plain equal-angle section must be defined on a separate line using the following format.

Format	Description	Dimension
S	Section name (e.g. "100x100x5.0 EA")	
S	Section material (must be defined in [Material], e.g. "C450L0")	
I	Unit combination code; 0 = (millimetres, newtons)	
F	Thickness ( $t$ )	L
F	Overall leg length ( $B$ )	L
F	Internal corner radius for all corners ( $R$ )	L

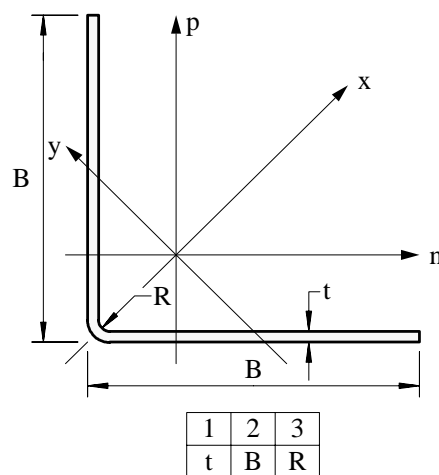

Fig. I.1 [PlainEqualAngle] definition

**[PlainUnequalAngle]: Specify a list of plain (unlipped) unequal-angle sections**

The profile geometry of a plain unequal-angle section is shown in Fig. I.2. Each plain unequal-angle section must be defined on a separate line using the following format.

Format	Description	Dimension
S	Section name (e.g. "75x50x5.0 UA")	
S	Section material (must be defined in [Material], e.g. "C450L0")	
I	Unit combination code; 0 = (millimetres, newtons)	
F	Thickness ( $t$ )	L
F	Overall leg length of longer (vertical) leg ( $B_1$ )	L
F	Overall leg length of shorter (horizontal) leg ( $B_2$ )	L
F	Internal corner radius for all corners ( $R$ )	L

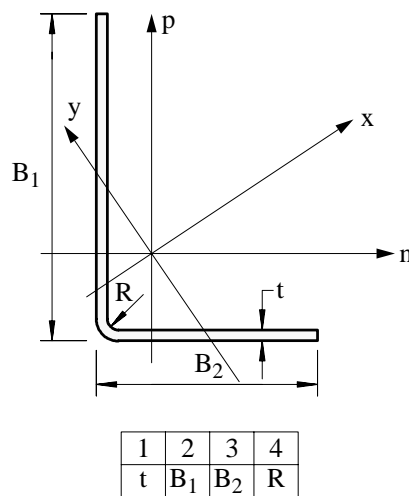

Fig. I.2 [PlainUnequalAngle] definition

**[PlainChannel]: Specify a list of plain (unlipped) channel sections**

The profile geometry of a plain channel section is shown in Fig. I.3. Each plain channel section must be defined on a separate line using the following format.

Format	Description	Dimension
S	Section name (e.g. "300x90x6.0 PFC")	
S	Section material (must be defined in [Material], e.g. "C450L0")	
I	Unit combination code; 0 = (millimetres, newtons)	
F	Thickness ( $t$ )	L
F	Overall depth ( $D$ )	L
F	Overall flange width ( $B$ )	L
F	Internal corner radius for all corners ( $R$ )	L

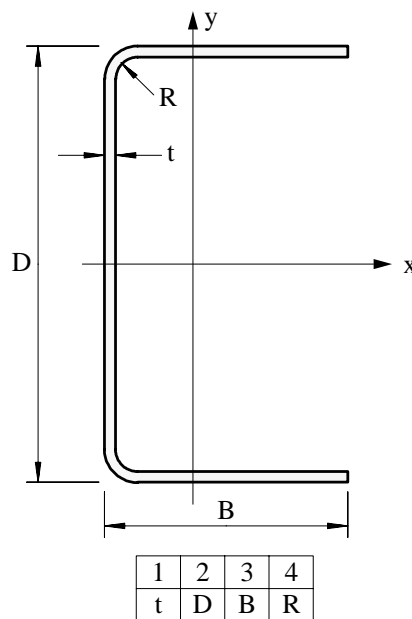

Fig. I.3 [PlainChannel] definition

**[LippedChannel]: Specify a list of lipped channel sections**

The profile geometry of a lipped channel section is shown in Fig. I.4. Each lipped channel section must be defined on a separate line using the following format.

Format	Description	Dimension
S	Section name (e.g. "C-10010")	
S	Section material (must be defined in [Material], e.g. "G450")	
I	Unit combination code; 0 = (millimetres, newtons)	
F	Thickness ( $t$ )	L
F	Overall depth ( $D$ )	L
F	Overall flange width ( $B$ )	L
F	Overall lip depth ( $L$ )	L
F	Internal corner radius for all corners ( $R$ )	L
[F]	Distortional buckling stress for bending about $x$ -axis ( $f_{odx}$ )	$F.L^{-2}$

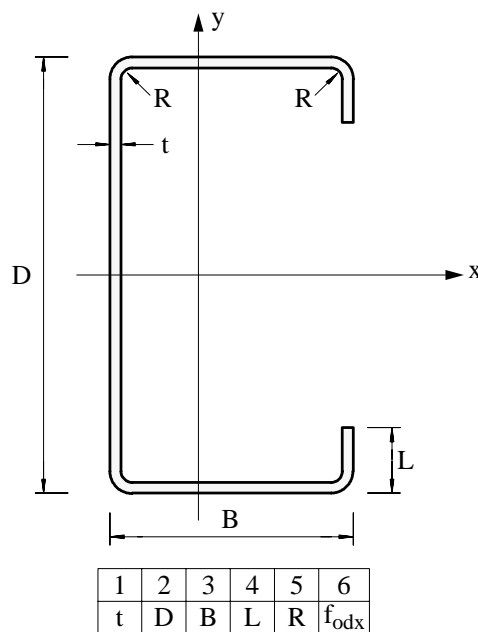

Fig. I.4 [LippedChannel] definition

**[PlainZed]: Specify a list of Plain Z-sections**

The profile geometry of a plain Z- section is shown in Fig. I.5. Each plain Z-section must be defined on a separate line using the following format.

Format	Description	Dimension
S	Section name (e.g. "PZ-10010")	
S	Section material (must be defined in [Material], e.g. "G450")	
I	Unit combination code; 0 = (millimetres, newtons)	
F	Thickness ( $t$ )	L
F	Overall depth ( $D$ )	L
F	Overall flange width ( $B$ )	L
F	Internal corner radius for all corners ( $R$ )	L

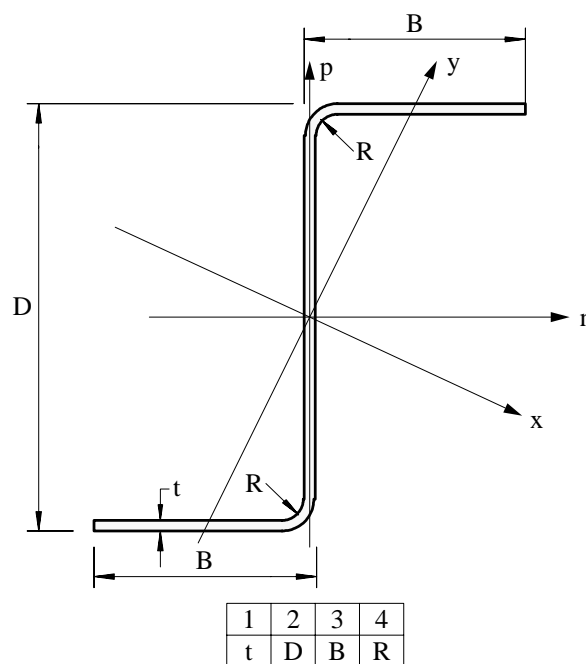

Fig. I.5 [PlainZed] definition

**[LippedZed]: Specify a list of lipped Z-sections**

The profile geometry of a lipped Z-section is shown in Fig. I.6. The two flanges of a Z-section may be of slightly unequal length to facilitate lapping, but not so different that its behaviour differs significantly from one with both flanges of equal and average width. In Fig. I.6, the bottom flange width is denoted  $E$  and the top flange width is denoted  $F$ .

Each lipped Z-section must be defined on a separate line using the following format.

Format	Description	Dimension
S	Section name (e.g. "Z-10010")	
S	Section material (must be defined in [Material], e.g. "G450")	
I	Unit combination code; 0 = (millimetres, newtons)	
F	Thickness ( $t$ )	L
F	Overall depth ( $D$ )	L
F	Overall width of bottom flange ( $E$ )	L
F	Overall width of top flange ( $F$ )	L
F	Overall lip depth ( $L$ )	L
F	Internal corner radius for all corners ( $R$ )	L
[F	Distortional buckling stress for bending about positive $n$ -axis ( $f_{odn+}$ )	F.L <sup>-2</sup>
F]	Distortional buckling stress for bending about negative $n$ -axis ( $f_{odn-}$ )	F.L <sup>-2</sup>

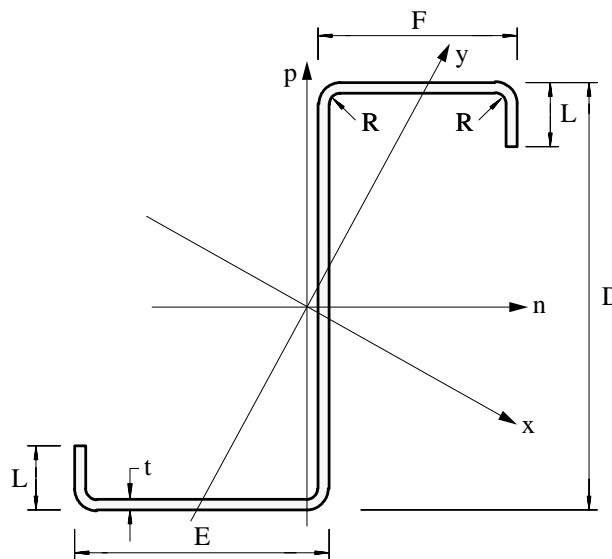

1	2	3	4	5	6	7	8
t	D	E	F	L	R	$f_{odn+}$	$f_{odn-}$

Fig. I.6 [LippedZed] definition

**[PlainHat]: Specify a list of plain (unlipped) hat sections**

The profile geometry of a plain hat section is shown in Fig. I.7. Each plain hat section must be defined on a separate line using the following format.

Format	Description	Dimension
S	Section name (e.g. "PH-10010")	
S	Section material (must be defined in [Material], e.g. "G450")	
I	Unit combination code; 0 = (millimetres, newtons, degrees)	
F	Thickness ( $t$ )	L
F	Overall depth ( $D$ )	L
F	Overall width of top flange ( $B$ )	L
F	Width of bottom flanges ( $F$ )	L
F	Internal corner radius for all bends ( $R$ )	L
F	Angle of webs from the vertical ( $\alpha$ )	A

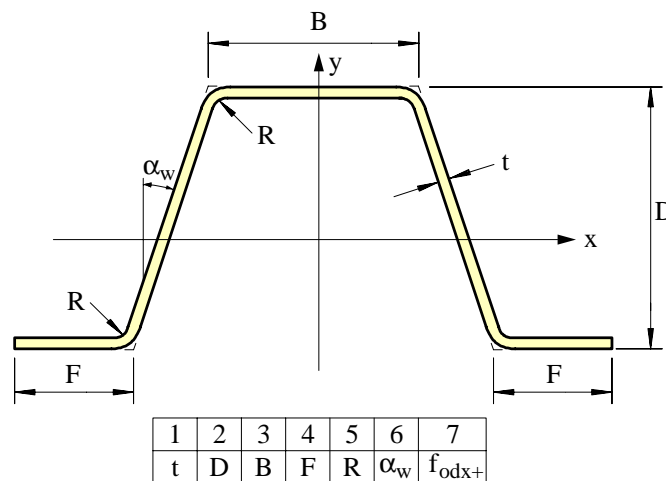

Fig. I.7 [PlainHat] definition

**[VeePlainHat]: Specify a list of plain (unlipped) hat sections with intermediate V-stiffener**

The profile geometry of a plain hat section with an intermediate V-stiffener is shown in Fig. I.8. Each plain hat section with an intermediate V-stiffener must be defined on a separate line using the following format.

Format	Description	Dimension
S	Section name (e.g. "VPH-10010")	
S	Section material (must be defined in [Material], e.g. "G450")	
I	Unit combination code; 0 = (millimetres, newtons, degrees)	
F	Thickness ( $t$ )	L
F	Overall depth ( $D$ )	L
F	Overall width of top flange ( $B$ )	L
F	Width of bottom flanges ( $F$ )	L
F	Overall depth of V-stiffener ( $V$ )	L
F	Internal corner radius for all bends at flange/web junctions ( $R_f$ )	L
F	Internal corner radius for all bends in V-stiffener ( $R_v$ )	L
F	Angle of webs from the vertical ( $\alpha_w$ )	A
F	Angle of sides of V-stiffener from the vertical ( $\alpha_v$ )	A

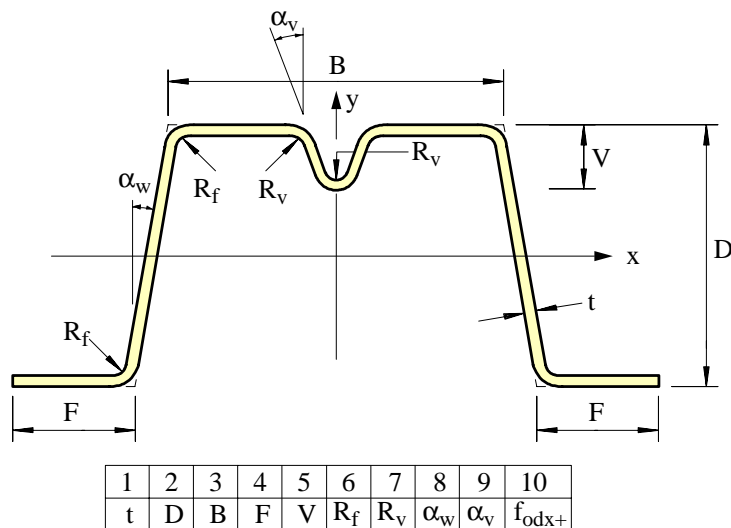
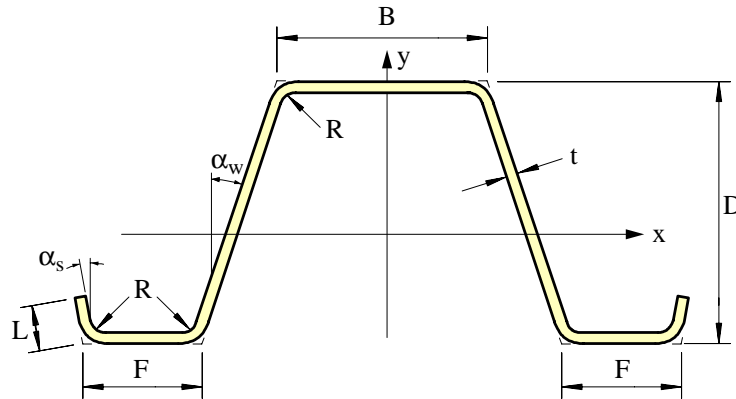

Fig. I.8 [VeePlainHat] definition

**[LippedHat]: Specify a list of lipped hat sections**

The profile geometry of a lipped hat section is shown in Fig. I.9. Each lipped hat section must be defined on a separate line using the following format.

Format	Description	Dimension
S	Section name (e.g. "LH-10010")	
S	Section material (must be defined in [Material], e.g. "G450")	
I	Unit combination code; 0 = (millimetres, newtons, degrees)	
F	Thickness ( $t$ )	L
F	Overall depth ( $D$ )	L
F	Overall width of top flange ( $B$ )	L
F	Width of bottom flanges ( $F$ )	L
F	Lip stiffener length ( $L$ )	L
F	Internal corner radius for all bends ( $R$ )	L
F	Angle of webs from the vertical ( $\alpha_1$ )	A
F	Angle of bottom flange stiffeners from vertical ( $\alpha_2$ )	A



1	2	3	4	5	6	7	8	9
$t$	$D$	$B$	$F$	$L$	$R$	$\alpha_w$	$\alpha_s$	$f_{odx+}$

Fig. I.9 [LippedHat] definition

**[VeeLippedHat]: Specify a list of lipped hat sections with intermediate V-stiffener**

The profile geometry of a lipped hat section with an intermediate V-stiffener is shown in Fig. I.10. Each lipped hat with an intermediate V-stiffener section must be defined on a separate line using the following format.

Format	Description	Dimension
S	Section name (e.g. "VLH-10010")	
S	Section material (must be defined in [Material], e.g. "G450")	
I	Unit combination code; 0 = (millimetres, newtons, degrees)	
F	Thickness ( $t$ )	L
F	Overall depth ( $D$ )	L
F	Overall width of top flange ( $B$ )	L
F	Width of bottom flanges ( $F$ )	L
F	Lip stiffener length ( $L$ )	L
F	Overall depth of V-stiffener ( $V$ )	L
F	Internal corner radius for all bends at flange/web junctions ( $R_f$ )	L
F	Internal corner radius for all bends in V-stiffener ( $R_v$ )	L
F	Angle of webs from the vertical ( $\alpha_w$ )	A
F	Angle of bottom flange stiffeners from vertical ( $\alpha_s$ )	A
F	Angle of sides of V-stiffener from the vertical ( $\alpha_v$ )	A

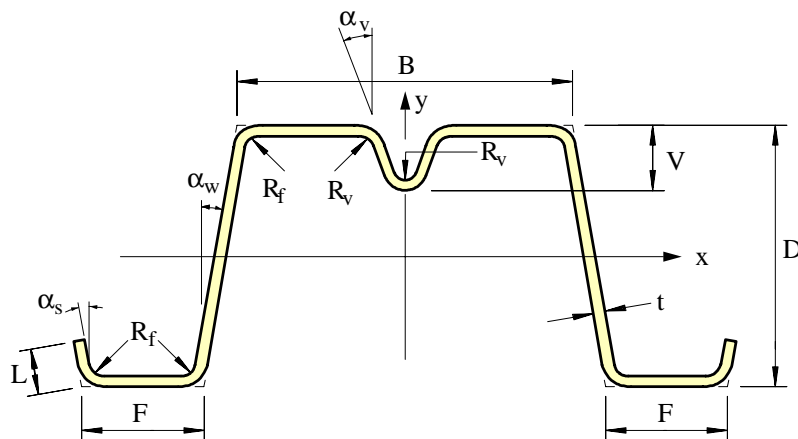

1	2	3	4	5	6	7	8	9	10	11	12
t	D	B	F	L	V	$R_f$	$R_v$	$\alpha_w$	$\alpha_s$	$\alpha_v$	$f_{odx+}$

Fig. I.10 [LippedHat] definition

**[SHS]: Specify a list of square hollow sections**

The assumed profile geometry of a square hollow section (SHS) is shown in Fig. I.11. Each square hollow section must be defined on a separate line using the following format.

Format	Description	Dimension
S	Section name (e.g. "100x100x5.0 SHS")	
S	Section material (must be defined in [Material], e.g. "G350")	
I	Unit combination code; 0 = (millimetres, newtons)	
F	Thickness ( $t$ )	L
F	Overall depth and width ( $B$ )	L
F	Internal corner radius for all corners ( $R$ )	L

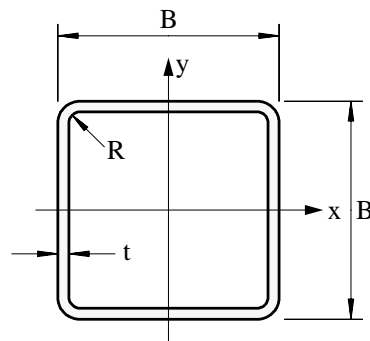

1	2	3
$t$	$B$	$R$

Fig. I.11 [SHS] definition

**[RHS]: Specify a list of rectangular hollow sections**

The assumed profile geometry of a rectangular hollow section (RHS) is shown in Fig. I.12. Each rectangular hollow section must be defined on a separate line using the following format.

Format	Description	Dimension
S	Section name (e.g. "100x50x5.0 RHS")	
S	Section material (must be defined in [Material], e.g. "G350")	
I	Unit combination code; 0 = (millimetres, newtons)	
F	Thickness ( $t$ )	L
F	Overall depth ( $D$ )	L
F	Overall width ( $B$ )	L
F	Internal corner radius for all corners ( $R$ )	L

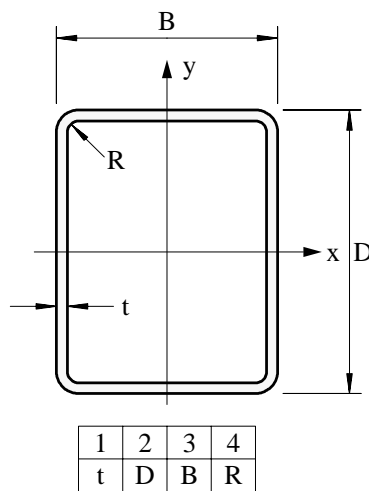

Fig. I.12 [RHS] definition

**[CHS]: Specify a list of circular hollow sections**

The assumed profile geometry of a circular hollow section (CHS) is shown in Fig. I.13. Each circular hollow section must be defined on a separate line using the following format.

Format	Description	Dimension
S	Section name (e.g. "100x5.0 CHS")	
S	Section material (must be defined in [Material], e.g. "G350")	
I	Unit combination code; 0 = (millimetres, newtons)	
F	Thickness ( $t$ )	L
F	Outside diameter ( $D$ )	L

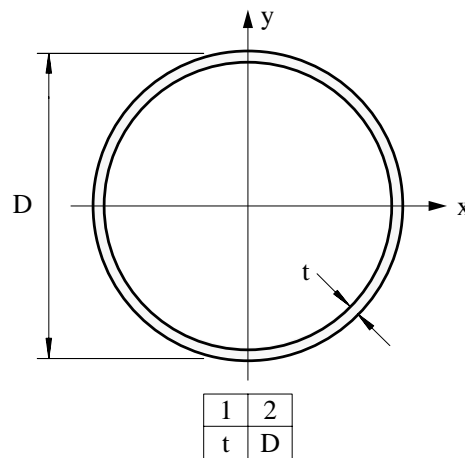

Fig. I.13 [CHS] definition

**Sample COLDSTEEL.INI File**

```

[Material]
"G450" 0 200000.0 80000.0 450.0 500.0 7.85e-6
"G500" 0 200000.0 80000.0 500.0 550.0 7.85e-6
"G550" 0 200000.0 80000.0 550.0 550.0 7.85e-6

[LippedChannel]
"C-10010" "G450" 0 1.0 102.0 51.0 12.5 5.0
"C-10012" "G450" 0 1.2 102.0 51.0 12.5 5.0
"C-10015" "G450" 0 1.5 102.0 51.0 13.5 5.0
"C-10019" "G450" 0 1.9 102.0 51.0 14.5 5.0
"C-15012" "G450" 0 1.2 152.0 64.0 14.5 5.0
"C-15015" "G450" 0 1.5 152.0 64.0 15.5 5.0
"C-15019" "G450" 0 1.9 152.0 64.0 16.5 5.0
"C-15024" "G450" 0 2.4 152.0 64.0 18.5 5.0
"C-20015" "G450" 0 1.5 203.0 76.0 15.5 5.0
"C-20019" "G450" 0 1.9 203.0 76.0 19.0 5.0
"C-20024" "G450" 0 2.4 203.0 76.0 21.0 5.0
"C-25019" "G450" 0 1.9 254.0 76.0 18.5 5.0
"C-25024" "G450" 0 2.4 254.0 76.0 20.5 5.0
"C-30024" "G450" 0 2.4 300.0 96.0 27.5 5.0
"C-30030" "G450" 0 3.0 300.0 96.0 31.5 5.0
"C-35030" "G450" 0 3.0 350.0 125.0 30.0 5.0

[LippedZed] // Narrow flange on top
"Z-10010" "G450" 0 1.0 102.0 53.0 49.0 12.5 5.0
"Z-10012" "G450" 0 1.2 102.0 53.0 49.0 12.5 5.0
"Z-10015" "G450" 0 1.5 102.0 53.0 49.0 13.5 5.0
"Z-10019" "G450" 0 1.9 102.0 53.0 49.0 14.5 5.0
"Z-15012" "G450" 0 1.2 152.0 65.0 61.0 15.5 5.0
"Z-15015" "G450" 0 1.5 152.0 65.0 61.0 16.5 5.0
"Z-15019" "G450" 0 1.9 152.0 65.0 61.0 17.5 5.0
"Z-15024" "G450" 0 2.4 152.0 65.0 60.0 19.5 5.0
"Z-20015" "G450" 0 1.5 203.0 79.0 74.0 15.0 5.0
"Z-20019" "G450" 0 1.9 203.0 79.0 74.0 18.5 5.0
"Z-20024" "G450" 0 2.4 203.0 79.0 73.0 21.5 5.0
"Z-25019" "G450" 0 1.9 254.0 79.0 74.0 18.0 5.0
"Z-25024" "G450" 0 2.4 254.0 79.0 73.0 21.0 5.0
"Z-30024" "G450" 0 2.4 300.0 100.0 93.0 27.0 5.0
"Z-30030" "G450" 0 3.0 300.0 100.0 93.0 31.0 5.0
"Z-35030" "G450" 0 3.0 350.0 129.0 121.0 30.0 5.0

```

## Appendix II. Section Properties

The calculation of full and effective section properties in **ColdSteel** is in accordance with Section 2 of AS/NZS 4600:1996. Two geometric models of the cross-section are employed in calculations: an “accurate” model and a “simplified” model.

The accurate model includes the geometry of the bends exactly and is used for the calculation of all properties which are directly related to section capacities, and the torsion constant  $J$ . In more detail, the properties based on the accurate section model include:

- full and effective cross-sectional area for the purposes of determining the nominal tensile capacity  $N_t$  and the nominal compressive capacities  $N_s$  and  $N_c$ ;
- full and effective section moduli for the purposes of determining nominal bending capacities  $M_{sx}$ ,  $M_{sy}$ ,  $M_{bx}$ ,  $M_{by}$ ,  $M_{sxf}$  and  $M_{syf}$ ;
- the radii of gyration,  $r_x$  and  $r_y$ ;
- the torsion constant  $J$ , which is based on the simplified formula

$$J = \sum_{\text{Elements } i} \frac{b_i t_i^3}{3} = \frac{w_f t^3}{3} \quad (\text{II.1})$$

in which  $b_i$  and  $t_i$  are the midline length and thickness of element  $i$  in the cross-section. In cold-formed sections, the thickness is constant and  $\sum b_i = w_f$ , in which  $w_f$  denotes the width of the feedstock.

The simplified cross-section models represent the section as an assembly of straight mid-line elements and may ignore the bends. Generally, the simplified model is employed in the calculation of all parameters related to the stability of members. These parameters include:

- the shear centre position,  $(x_o, y_o)$ ;
- the polar radius of gyration of the cross-section about the shear centre ( $r_o$ );
- the warping constant ( $I_w$ );
- the monosymmetry parameters ( $\beta_x$  and  $\beta_y$ ).

Using the simplified section geometry, the above parameters are calculated according to Vlasov's theory (Vlasov 1961) for thin-walled beams. All the above parameters relate to the full section.

For effective width calculations, each element of the cross-section is assumed to be of a specific type. Examples of different types of elements include unstiffened elements, stiffened elements, elements with an edge stiffener, and elements with one or more intermediate stiffeners. In the case of a plain (unlipped) channel section, for example, each flange is assumed to be an unstiffened element, and the web is assumed to be a stiffened element.

Furthermore, the effective width rules to be applied to such elements may vary depending on whether the element is in uniform compression or is subjected to a stress gradient. The corner regions are always fully effective. It should be noted that **ColdSteel** has enormous flexibility and power in modelling the complex geometries of some commercial profiles. The modelling is performed in such a manner that the physical purpose of the element is understood and effective width calculations are facilitated even if the “complex” element comprises many “sub-elements”.

The philosophy and procedures pertaining to effective width calculations differ between stiffened and unstiffened elements. In both cases, the starting point for calculations is an assumed stress distribution acting over the gross section (accurate model including bends). From this stress distribution, the stresses  $f_1^*$  and  $f_2^*$  acting at the ends of the element are determined (see Fig. II.1). Each of these stresses is calculated at the *midline* of the element concerned and not at an extreme fibre. For calculation purposes, it is assumed that  $f_1^*$  and  $f_2^*$  are positive in compression, negative in tension, and that  $f_1^* \geq f_2^*$ .

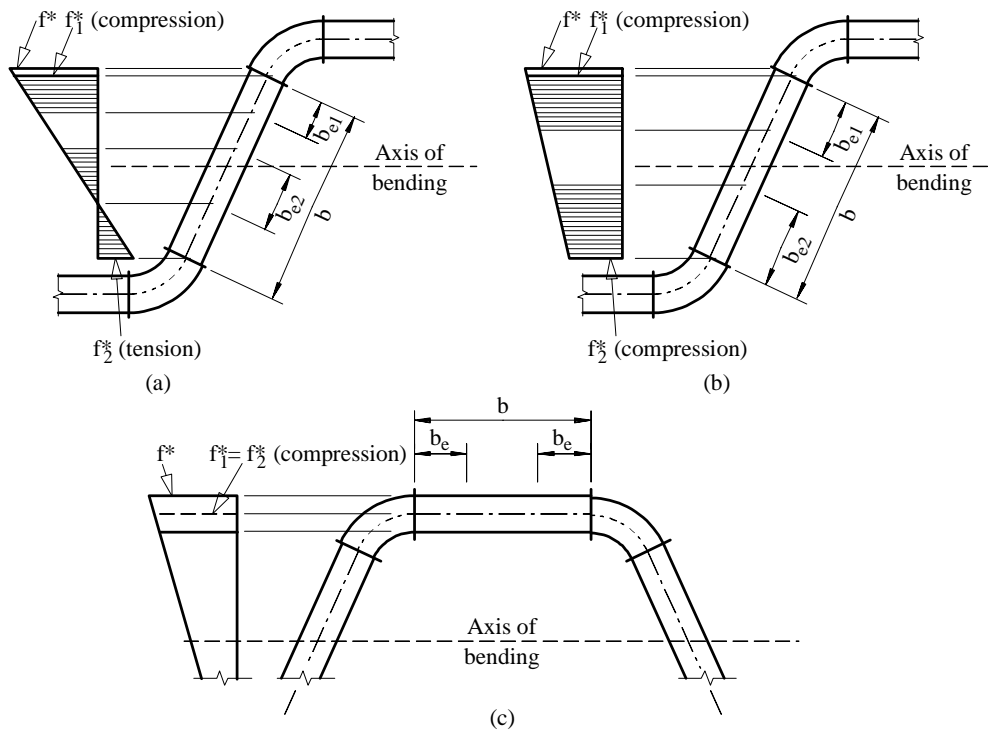

Fig. II.1 Effective widths of stiffened elements subjected to stress gradient and uniform compression, and definitions of  $f_1^*$ ,  $f_2^*$  and  $f^*$ .

For stiffened elements, the plate buckling coefficient  $k$  is determined using Eq. 2.2.3.1(4) of AS/NZS 4600:1996

$$k = 4 + 2(1 - \psi)^3 + 2(1 - \psi) \quad (\text{II.2})$$

in which the stress ratio  $\psi$  is given by

$$\psi = \frac{f_2^*}{f_1^*} \quad (\text{II.3})$$

For unstiffened elements, AS/NZS 4600:1996 provides two options for the calculation of the plate buckling coefficient  $k$ . In line with the AISI Specification (AISI 1996) on which AS/NZS 4600:1996 is closely based, the constant value of

$$k = 0.43 \quad (\text{II.4})$$

is assumed. Alternatively, the rationale outlined in Appendix F (Table F1) of AS/NZS 4600:1996 can be used in which  $k$  is expressed as a function of the stress gradient parameter  $\psi$ .

After the plate buckling coefficients have been determined, the effective widths for the plate elements in the cross-section can be calculated. For this purpose, the stress  $f^*$  used in calculating the element slenderness  $\lambda$

$$\lambda = \frac{1.052}{\sqrt{k}} \left( \frac{b}{t} \right) \sqrt{\frac{f^*}{E}} \quad (\text{II.5})$$

is equal to the maximum compressive stress in the element as shown in Fig. II.1 for stiffened elements.

Based on the resulting effective section, effective cross-sectional properties such as area, centroid and second moments of area can be determined. If the centroid of the effective section differs from the centroid of the gross section, then the ratio  $\psi$  of the stresses at the ends of each element may change; this leads to

the question of whether a new plate buckling coefficient  $k$ , and hence new effective lengths, should be computed for the various elements in the cross-section. If so, the whole effective section computation procedure is iterative until “convergence” is achieved. In relation to AS/NZS 4600:1996, the following philosophy is adopted for stiffened and unstiffened elements:

- For *stiffened elements*, effective width calculations are *iterative*, i.e., the plate buckling coefficient is computed based on the current effective section (or full section if it's the first iteration), which in turn leads to new effective widths, new centroid, new stress ratio  $\psi$ , new stress  $f^c$ , and so on.
- For *unstiffened elements*, the adoption of  $k = 0.43$  automatically ensures that effective width calculations are *not iterative* for those elements. Similarly, if Appendix F is utilised, the values of  $\psi$  and  $k$  which should be adopted for each unstiffened element are *uniquely determined* by the stress gradient  $\psi$  pertaining to the full section. This approach is consistent with the philosophy employed in Eurocode 3 (CEN 1996) from which Appendix F is drawn. As the position of the effective centroid changes from iteration to iteration, the stress  $f^c$  used in Eq. (II.5) may also change. In all cases, however,  $f^c$  is the maximum compressive stress in the element.

Therefore, it may be stated that effective section calculations in AS/NZS 4600:1996 are iterative in principle when the cross-section is subjected to a stress gradient. The stress ratio  $\psi$  and plate buckling coefficient  $k$  pertaining to a stiffened element may change throughout the iterative process as the effective section changes. On the other hand, the values of  $\psi$  and  $k$  used for an unstiffened element, whether based on Eq. (II.4) above or Appendix F of AS/NZS 4600:1996, are uniquely determined from the initial stress distribution assumed to act over the gross-section. If the cross-section is subjected to a uniform stress distribution, effective section calculations entail no iteration.

## Appendix III. Summary of Member Design Checks

ColdSteel performs design checks for member strength limit states only. The notation used in the following is generally the same as that in AS/NZS 4600:1996 except with some minor modifications.

### III.1 Tension (Clause 3.2)

Members subjected to a design tension force  $N^*$  (positive) must satisfy

$$N^* \leq \phi_t N_{ty} \quad (\text{III.1})$$

$$N^* \leq \phi_t N_{tu} \quad (\text{III.2})$$

where  $N_{ty} = A_g f_y$  is the nominal tensile capacity relating to failure by yielding of the gross section,  $N_{tu} = 0.85 k_t A_n f_u$  is the nominal tensile capacity relating to fracture through the net section, and  $\phi_t (= 0.9)$  is the capacity factor for members subject to tension. The net area  $A_n$  is computed as  $A_n = A_g - b_r t$ , in which  $b_r$  is the length of the cross-section perimeter which is removed due to bolt holes, accounting appropriately for staggers if relevant.

### III.2 Bending (Clause 3.3)

Members subjected to a design bending moment  $M_x^*$  about the principal  $x$ -axis must satisfy

$$M_x^* \leq \phi_b M_{sx} \quad (\text{III.3})$$

$$M_x^* \leq \phi_b M_{bx} \quad (\text{III.4})$$

in which  $M_{sx}$  is the nominal section capacity based on the initiation of yielding in the effective section, and  $M_{bx}$  is the nominal member (lateral buckling) moment capacity for bending about the  $x$ -axis. As defined in Table 1.6 of AS/NZS 4600:1996, the capacity factor  $\phi_b$  for section strength in bending is equal to 0.95 if the elements in compression are stiffened elements, or 0.9 if the elements in compression are unstiffened elements. The relevant capacity factors are defined appropriately by ColdSteel. As far as bending strength governed by lateral buckling is concerned, the capacity factor  $\phi_b$  is equal to 0.9 universally.

Members subjected to a design bending moment  $M_y^*$  about the principal  $y$ -axis must satisfy

$$M_y^* \leq \phi_b M_{sy} \quad (\text{III.5})$$

$$M_y^* \leq \phi_b M_{by} \quad (\text{III.6})$$

in which  $M_{sy}$  is the nominal section capacity based on the initiation of yielding in the effective section, and  $M_{by}$  is the nominal member (lateral buckling) moment capacity for bending about the  $y$ -axis.

### III.3 Shear (Clause 3.3.4)

Members subjected to design shear forces  $V_x^*$  and  $V_y^*$  in the  $x$  and  $y$ -axis directions must satisfy

$$V_x^* \leq \phi_v V_{vx} \quad (\text{III.7})$$

$$V_y^* \leq \phi_v V_{vy} \quad (\text{III.8})$$

in which  $V_{vx}$  and  $V_{vy}$  are the corresponding nominal shear capacities, and  $\phi_v (= 0.9)$  is the capacity factor for members subjected to shear. To circumvent the difficulty associated with the fact that the design shear

forces  $V_x^*$  and  $V_y^*$  are in the axis directions, but the capacities of the individual cross-section elements to resist shear vary according to their orientation, the shear capacities are computed using

$$V_{vx} = \sum_{\substack{\text{Flat} \\ \text{Elements}}} V_v |\cos \theta| \quad (\text{III.9})$$

$$V_{vy} = \sum_{\substack{\text{Flat} \\ \text{Elements}}} V_v |\sin \theta| \quad (\text{III.10})$$

in which  $\theta$  is the orientation of the straight element with respect to the  $x$ -axis of the full section and the summation occurs over all flat elements in the accurate cross-section model. Corners and lip stiffeners are assumed not to contribute to the shear resistance. The shear capacity term  $V_v$  is computed using a slight modification of Eqs. 3.3.4(1) to 3.3.4(3) in AS/NZS 4600:1996:

$$\begin{aligned} \text{For } \frac{b/t}{\sqrt{Ek_v/f_y}} \leq 1: & \quad V_v = 0.64 f_y b t \\ \text{For } 1 < \frac{b/t}{\sqrt{Ek_v/f_y}} \leq 1.415: & \quad V_v = 0.64 t^2 \sqrt{Ek_v f_y} \\ \text{For } \frac{b/t}{\sqrt{Ek_v/f_y}} > 1.415: & \quad V_v = 0.905 Ek_v t^3 / b \end{aligned} \quad (\text{III.11})$$

in which  $b$ ,  $t$  and  $k_v$  are length, thickness and shear buckling coefficient, respectively, of the flat element being considered. **ColdSteel** assumes that none of the plate elements are stiffened with transverse stiffeners, and with this assumption the shear buckling coefficient is given as  $k_v = 5.34$  in AS/NZS 4600:1996 for webs. Implicit in the value of  $k_v = 5.34$ , however, is the assumption that the element is supported on both edges by other plate elements, as would be the case with the web of a channel section. Since there is no guidance given in AS/NZS 4600:1996 as to what values of  $k_v$  should be assumed for unstiffened elements (the flanges of an unlippped channel and both legs of an unlippped angle, for example), the value of  $k_v = 5.34$  has also been used for these elements. It should be noted that AS/NZS 4600:1996 does not specifically preclude the application of  $k_v = 5.34$  to unstiffened elements in shear.

#### III.4 Combined Bending and Shear (Clause 3.3.5)

For the general case of a member subjected to design moments  $M_x^*$  and  $M_y^*$  and shear forces  $V_x^*$  and  $V_y^*$ , the capacity in combined bending and shear is required to be checked independently in a uniaxial sense according to

$$\left( \frac{V_y^*}{\phi_v V_{vy}} \right)^2 + \left( \frac{M_x^*}{\phi_b M_{sx}} \right)^2 \leq 1.0 \quad (\text{III.12})$$

$$\left( \frac{V_x^*}{\phi_v V_{vx}} \right)^2 + \left( \frac{M_y^*}{\phi_b M_{sy}} \right)^2 \leq 1.0 \quad (\text{III.13})$$

as given in Clause 3.3.5 of AS/NZS 4600:1996 for beams with unstiffened webs.

#### III.5 Bearing (Clause 3.3.6)

The bearing capacity which is checked in **ColdSteel** relates to a vertical bearing load  $R_y^*$  for which the corresponding nominal bearing capacity  $R_{by}$  is defined in Tables 3.3.6(1) or 3.3.6(2) of AS/NZS 4600:1996. The corresponding capacity factor  $\phi_w$  for bearing is equal to 0.75. The bearing load parameters  $l_b$ ,  $c$  and  $e$

are supplied as input parameters to **ColdSteel**. If the distance  $e$  between opposing bearing loads is less than 1.5 times the web depth  $d_1$  as defined in Tables 3.3.6(1) or 3.3.6(2), then the bearing involves two opposite loads or reactions. If  $e > 1.5d_1$ , a single load or reaction is assumed to be involved.

### III.6 Combined Bending and Bearing (Clause 3.3.7)

For the case of a member subjected to a design moment  $M_x^*$  and a bearing load  $R_y^*$ , the capacity is checked according to

$$1.07 \left( \frac{R_y^*}{\phi_w R_{by}} \right) + \left( \frac{M_x^*}{\phi_b M_{sx}} \right) \leq 1.42 \quad (\text{III.14})$$

for shapes having single unstiffened webs.

### III.7 Compression (Clause 3.4)

Members subjected to a design compressive force  $N^*$  which acts through the centroid of the *effective section* must satisfy

$$N^* \leq \phi_c N_s \quad (\text{III.15})$$

$$N^* \leq \phi_c N_c \quad (\text{III.16})$$

in which

$N_s = A_e f_y$ , with the effective area  $A_e$  calculated at the yield stress ( $f_y$ )

$N_c = A_e f_n$ , with the effective area  $A_e$  calculated at the inelastic critical stress ( $f_n$ ).

The capacity factor  $\phi_c$  for concentrically loaded compression members is equal to 0.85. The clauses in AS/NZS 4600:1996 relating to distortional buckling are not relevant for any of the sections currently included in **ColdSteel**.

It should be noted that in the usual case, the design axial force  $N^*$  as computed by the structural analysis is assumed to act through the centroid of the *full* rather than the *effective* cross section. In this case, the member must be designed for the additional design moments resulting from the eccentricity of the axial force from the effective centroid. Furthermore, for angle sections, the effect of the design compressive axial force  $N^*$  acting through an eccentricity  $e_x = L/1000$  causing a moment equal to  $N^* L/1000$  applied about the minor axis causing compression in the tips of the legs, must be considered.

### III.8 Combined Axial Compressive Load and Bending (Clause 3.5.1)

The design axial compressive load  $N^*$  and the design bending moments  $M_x^*$  and  $M_y^*$  about the principal  $x$  and  $y$ -axes must satisfy the following two inequalities:

$$\frac{N^*}{\phi_c N_s} + \frac{M_x^*}{\phi_b M_{bx}} + \frac{M_y^*}{\phi_b M_{by}} \leq 1.0 \quad (\text{III.17})$$

$$\frac{N^*}{\phi_c N_c} + \frac{C_{mx} M_x^*}{\phi_b M_{bx} \alpha_{nx}} + \frac{C_{my} M_y^*}{\phi_b M_{by} \alpha_{ny}} \leq 1.0 \quad (\text{III.18})$$

where it should be borne in mind that  $\phi_b M_{bx} \leq \phi_b M_{sx}$  and  $\phi_b M_{by} \leq \phi_b M_{sy}$ . In essence, Eq. (III.17) constitutes the critical strength check where the moment amplification is not sufficient to cause the maximum moments within the length of the member to exceed the maximum first-order values. If there are no transverse loads on the member, the position of maximum moment will be at one of the member ends. Equation (III.18) allows for the effects of moment amplification on the design moment distributions about the  $x$  and  $y$ -axes.

If  $N^*/\phi_c N_c \leq 0.15$ , the following interaction may be used in lieu of Eqs. (III.17) and (III.18):

$$\frac{N^*}{\phi_c N_c} + \frac{M_x^*}{\phi_b M_{bx}} + \frac{M_y^*}{\phi_b M_{by}} \leq 1.0 \quad (\text{III.19})$$

### III.9 Combined Axial Tensile Load and Bending (Clause 3.5.2)

The design axial tensile load  $N^*$  and the design bending moments  $M_x^*$  and  $M_y^*$  about the principal  $x$  and  $y$ -axes must satisfy the following inequalities:

$$\frac{N^*}{\phi_t N_t} + \frac{M_x^*}{\phi_b M_{sxf}} + \frac{M_y^*}{\phi_b M_{syf}} \leq 1.0 \quad (\text{III.20})$$

$$\frac{M_x^*}{\phi_b M_{bx}} + \frac{M_y^*}{\phi_b M_{by}} - \frac{N^*}{\phi_t N_t} \leq 1.0 \quad (\text{III.21})$$

It should be noted from Eq. (III.21) that the nominal strength of a member subjected to bending and tension may be greater than that of the same member subjected to the corresponding bending moments only.

## Appendix IV. Error and Warning Codes

E = Error

W = Warning

- E 100 Invalid unit of length
- E 101 Invalid unit of force
- E 102 Invalid unit of mass
- E 110 Invalid axis system
- E 111 Invalid procedure for calculation of  $M_c$  (Clause 3.3.3.2)
- E 112 Invalid parameter relating to effective widths of unstiffened elements
- E 113 Invalid parameter for calculation of  $M_{cx}$  (Clause 3.3.3.2)
- E 114 Invalid parameter for calculation of  $M_{cx}$  when  $C_{bx}/C_{mx} = 1.0$  (Clause 3.3.3.2)
- E 115 Invalid parameter for calculation of  $M_{ox}$  (Clause 3.3.3.2)
- E 116 Invalid parameter for calculation of  $M_{ox}$  when  $C_{bx}/C_{mx} = 1.0$  (Clause 3.3.3.2)
- E 117 Invalid parameter for calculation of  $N_c$
- E 118 Invalid parameter for calculation of  $N_{oc}$
- E 119 Invalid option for inclusion of  $L/1000$  eccentricity for angle sections
- E 120 Invalid R-factor option
- E 121 Invalid option for distortional buckling capacity in compression ( $N_{od}$ )
- E 122 Invalid option for distortional buckling capacity in bending about  $x$ -axis ( $M_{odx}$ )
- E 123 Invalid option for distortional buckling capacity in bending about  $y$ -axis ( $M_{ody}$ )
- E 124 Invalid option for transverse loads for bending about  $x$ -axis
- E 125 Invalid option for transverse loads for bending about  $y$ -axis
- E 130 Invalid type of cross-section
- E 131 Invalid cross-section dimension
- E 140 Invalid Young's modulus ( $E$ )
- E 141 Invalid shear modulus ( $G$ )
- E 142 Invalid yield stress ( $f_y$ )
- E 143 Invalid tensile strength ( $f_u$ )
- E 144 Invalid material density ( $\rho$ )
- E 150 Invalid  $k_t$  factor for tension capacity
- E 151 Invalid amount of material removed ( $b_r$ ) for tension capacity
- E 152 Invalid amount of material removed for tension capacity ( $b_r > b$ )
- E 160 Invalid member actual length ( $L$ )
- E 161 Invalid member effective length ( $L_{ex}$ )
- E 162 Invalid member effective length ( $L_{ey}$ )
- E 163 Invalid member effective length ( $L_{ez}$ )
- E 164 Elastic critical buckling load ( $N_{oc}$ ) from rational buckling analysis is zero
- W 165 Invalid effective length ( $L_{ex}/r_x > 200$ )
- W 166 Invalid effective length ( $L_{ey}/r_y > 200$ )
- E 167 Invalid set of effective lengths  $L_{ex}, L_{ey}, L_{ez}; f_{oc}$  is negative

- E 170 Invalid moment factor ( $C_{bx}$ ) for calculation of  $M_{ox}$  (Clause 3.3.3.2(a))
- E 171 Invalid moment factor ( $C_{by}$ ) for calculation of  $M_{oy}$  (Clause 3.3.3.2(a))
- E 172 Invalid moment factor ( $C_{mx}$ ) for calculation of  $M_{ox}$  (Clause 3.3.3.2(a))
- E 173 Invalid moment factor ( $C_{my}$ ) for calculation of  $M_{oy}$  (Clause 3.3.3.2(a))
- E 174 Invalid moment factor ( $C_{mx}$ ) for calculation of  $M_{ox}$  (Clause 3.3.3.2(b))
- E 175 Invalid moment factor ( $C_{my}$ ) for calculation of  $M_{oy}$  (Clause 3.3.3.2(b))
- E 176 Invalid moment factor ( $C_{mx}$ ) for use in combined actions
- E 177 Invalid moment factor ( $C_{my}$ ) for use in combined actions
- E 178 Elastic critical buckling moment ( $M_{ox}$ ) from rational buckling analysis is zero
- E 180 Invalid bearing length ( $l_b$ )
- E 181 Invalid bearing length ( $c$ )
- E 182 Invalid bearing length ( $e$ )
- E 183 Web too slender for bearing ( $d_1/t_w > 200$ )
- E 184 Bearing length too long ( $l_b/t_w > 210$ )
- E 185 Bearing length too long ( $l_b/d_1 > 3.5$ )
- W 186 Bearing equations not valid ( $r_1/t_w > 6.0$ ) (Clause 3.3.6)
- W 190 Distortional buckling stress ( $f_{odc}$ ) from rational buckling analysis is zero; Appendix D was used instead
- W 191 Distortional buckling stress ( $f_{odx}$ ) from rational buckling analysis is zero; Appendix D was used instead
- W 192 Distortional buckling stress ( $f_{ody}$ ) from rational buckling analysis is zero; Appendix D was used instead
- W 193 Distortional buckling stress ( $f_{ody}$ ) from rational buckling analysis is zero; Appendix D was used instead
- W 194 Distortional buckling stress ( $f_{ody}$ ) from rational buckling analysis is zero; Appendix D was used instead
- E 195 Distortional buckling stress in pure compression ( $f_{odc}$ ) is negative (Appendix D)
- E 200 Invalid R-factor
- E 210 Invalid deflection limit for serviceability calculation
- E 211 Invalid type of beam for serviceability calculation
- W 220 Unstiffened element too slender,  $(b/t)_{limit} = 60$  (Clause 2.1.3)
- W 221 Stiffened element too slender,  $(b/t)_{limit} = 200$  (Clause 2.1.3)
- W 222 Edge stiffened element too slender (Clause 2.1.3)
- E 223 Circular section too slender,  $d_o/t > 0.441E/f_y$  (Clause 3.6.1)

## Appendix V. References

AISI (1996), *Specification for the Design of Cold-Formed Steel Structural Members*, 1996 Edition (Printed 1 June 1997), Cold-Formed Steel Design Manual—Part V, American Iron and Steel Institute, Washington DC.

CASE (1997a), *PRFELB—A Computer Program for Finite Element Flexural-Torsional Buckling Analysis of Plane Frame*, Version 3.0, Centre for Advanced Structural Engineering, Department of Civil Engineering, The University of Sydney, April 1997.

CASE (1997b), *ThinWall—A Computer Program for Cross-Section Analysis and Finite Strip Buckling Analysis of Thin-Walled Structures, User's Manual*, Version 1.2, Centre for Advanced Structural Engineering, Department of Civil Engineering, The University of Sydney, April 1997.

CEN (1996), *ENV 1993-1-3:1996 Eurocode 3: Design of Steel Structures, Part 1.3 Supplementary rules for cold-formed thin gauge members and sheeting*, edited draft 9 February 1996, European Committee for Standardisation, Brussels.

CCFSS (1992), "Four Span Continuous Z-Purlin Design Example", *CCFSS Technical Bulletin*, Vol. 1, No. 2, Center for Cold-Formed Steel Structures, University of Missouri–Rolla, August.

Hancock, G. J. (1998), *Design of Cold-Formed Steel Structures*, 3rd Edition, Australian Institute of Steel Construction, Sydney.

Serette, R. L. & Peköz, T. (1995), "Distortional Buckling of Thin-Walled Beams/Panels. I: Theory", *Journal of Structural Engineering*, American Society of Civil Engineers, Vol. 121, No. 4, pp. 757–766.

SA (1990), *AS 4100-1990, Steel Structures*, Standards Australia, Sydney, 1990

SA/SNZ (1996), *AS/NZS 4600:1996, Cold-Formed Steel Structures*, Standards Australia/ Standards New Zealand, 1996.

SA/SNZ (1998), *AS/NZS 4600 Supplement 1:1998, Cold-Formed Steel Structures—Commentary (Supplement 1 to AS/NZS 4600:1996)*, Standards Australia/ Standards New Zealand, 1998.

Trahair, N.S. (1993), *Flexural-Torsional Buckling of Structures*, Chapman & Hall, First Edition, London.

Vlasov, V.Z. (1961), *Thin-walled Elastic Beams*, 2nd edition, Israel Program for Scientific Translations, Jerusalem.