

THIN-WALL



Centre for
Advanced
Structural
Engineering

<http://www.civil.usyd.edu.au/case/software.shtml>

Introduction

THIN-WALL is a user-friendly computer program for calculating the section properties and stresses in thin-walled cross-sections of general geometry. The program calculates the section properties, sectorial coordinate, and the longitudinal and shear stresses for the cross-section. THIN-WALL can also perform an elastic buckling analysis of thin-walled structures subjected to longitudinal stress. The structure being analysed may be a folded plate system, a stiffened plate or a thin-walled structural member but it must be uniform in thickness in the longitudinal direction and simply supported at its ends. The longitudinal edges may be simply supported, clamped or free along the full length of the plate system. The analysis can be done for a number of different buckle half-wavelengths of the structure and the load factor and buckled shape are output for each length.

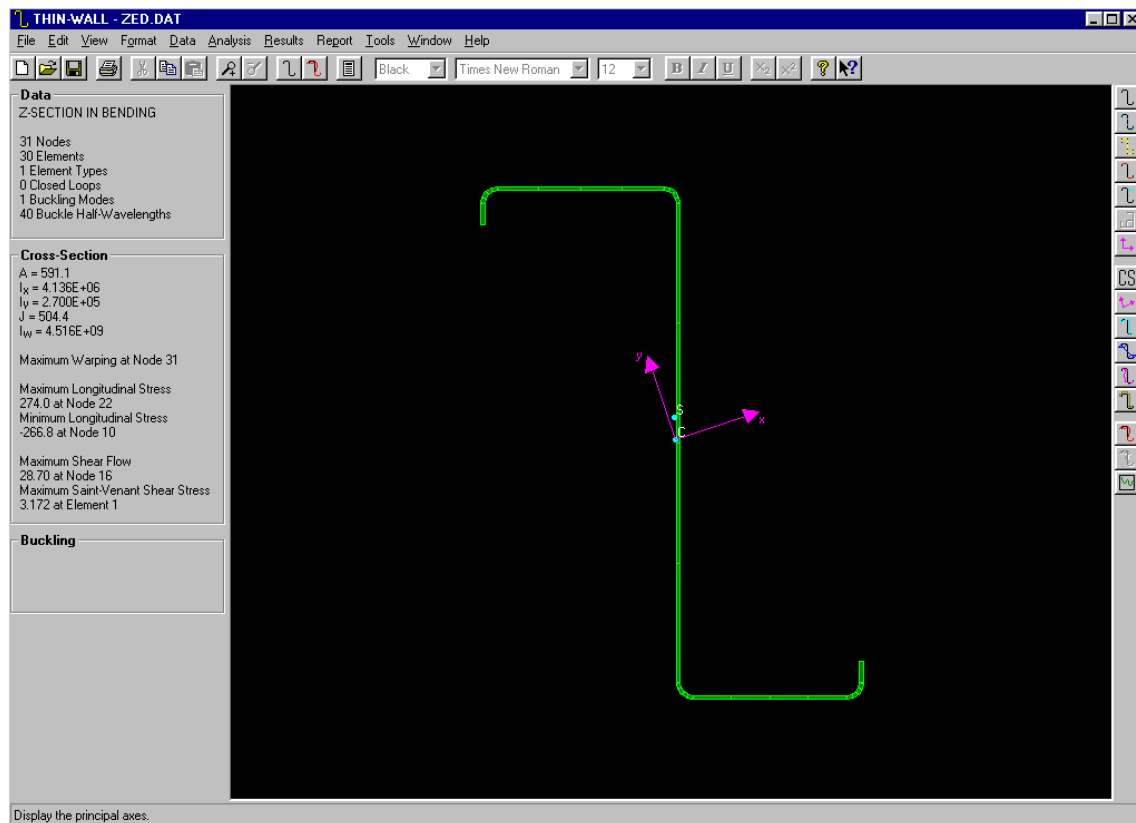

Data

The input data for a cross-section is similar to the data for a plane structural framework being analysed on a computer. To achieve this similarity, a thin-walled cross-section should be subdivided into an assemblage of rectangular elements. The ends of the elements intersect at nodes. The input data for the program includes the geometry of the cross-section and the stress resultants acting at the cross-section. A user-friendly data processor can be used for the creation of data for a new section or for the modification of data for an existing section. Help screens provide advice concerning the nature of the data required, and a facility exists for the automatic generation of the node and element numbers for many standard sections.

Nodes and Elements

Node Number	X	Y	Longitudinal Stress
1	-77.4	86.5	-226.28
2	-77.4	94.9	-248.86
3	-76.959	97.12	-254.84
4	-75.701	99.001	-259.93
5	-73.82	100.26	-263.38
6	-71.6	100.7	-264.63
7	-55.15	100.7	-265.17
8	-38.7	100.7	-265.71
9	-22.25	100.7	-266.26
10	-5.8	100.7	-266.8

Element Number	Node 1	Node 2	Type Number
1	1	2	1
2	2	3	1
3	3	4	1
4	4	5	1
5	5	6	1
6	6	7	1
7	7	8	1
8	8	9	1
9	9	10	1
10	10	11	1

Standard Section

Width

D: 152, B1: 65, L1: 15, B2: 61, L2: 15

Thickness

T: 1.2

Corner Radius

R1: 5, R2: 5, R3: 5, R4: 5

Angle

theta1: 90, theta2: 90

Material

E: 200000, G: 80000, nu: .3



Cross-Section Analysis

The cross-section analysis of THIN-WALL is based on a general matrix method for analysing the section properties and stresses in thin-walled open and closed cross-sections of any shape. The analysis calculates the section properties, sectorial coordinate, and the longitudinal and shear stresses caused by flexure and torsion. The section properties computed include area, second moment of area, section modulus, coordinates of centroid and shear centre, torsion constant, warping constant and monosymmetry parameters. Also computed are the longitudinal stresses caused by axial force, flexural moment and bimoment, and the shear stresses caused by shear force and torsion. Plots of sectorial coordinate (warping pattern), longitudinal stress and shear stress can be drawn on the screen.

Section Properties	
Area of section	$A = 591.1$
2nd moment of area about rectangular axes	$I_{x'} = 3.749E+06$ $I_{y'} = 6.571E+05$
Section modulus about rectangular axes	$Z_{x'} = 3.673E+04$ $Z_{y'} = 8620$
Product moment of area	$I_{x'y'} = -1.160E+06$
2nd moment of area about principal axes	$I_x = 4.136E+06$ $I_y = 2.700E+05$
Section modulus about principal axes	$Z_x = 3.489E+04$ $Z_y = 5951$
Torsion constant	$J = 504.4$
Warping constant	$I_w = 4.516E+09$
Coordinates of centroid	$X_C = -1.172$ $Y_C = 1.363$
Coordinates of shear centre	$X_S = -1.650$ $Y_S = 9.948$
Coordinates of shear centre in principal axes	$x_0 = 2.262$ $y_0 = 8.296$
Monosymmetry parameters	$\beta_x = -17.59$ $\beta_y = -17.11$
Slope of principal axes	$\alpha = 18.45^\circ$

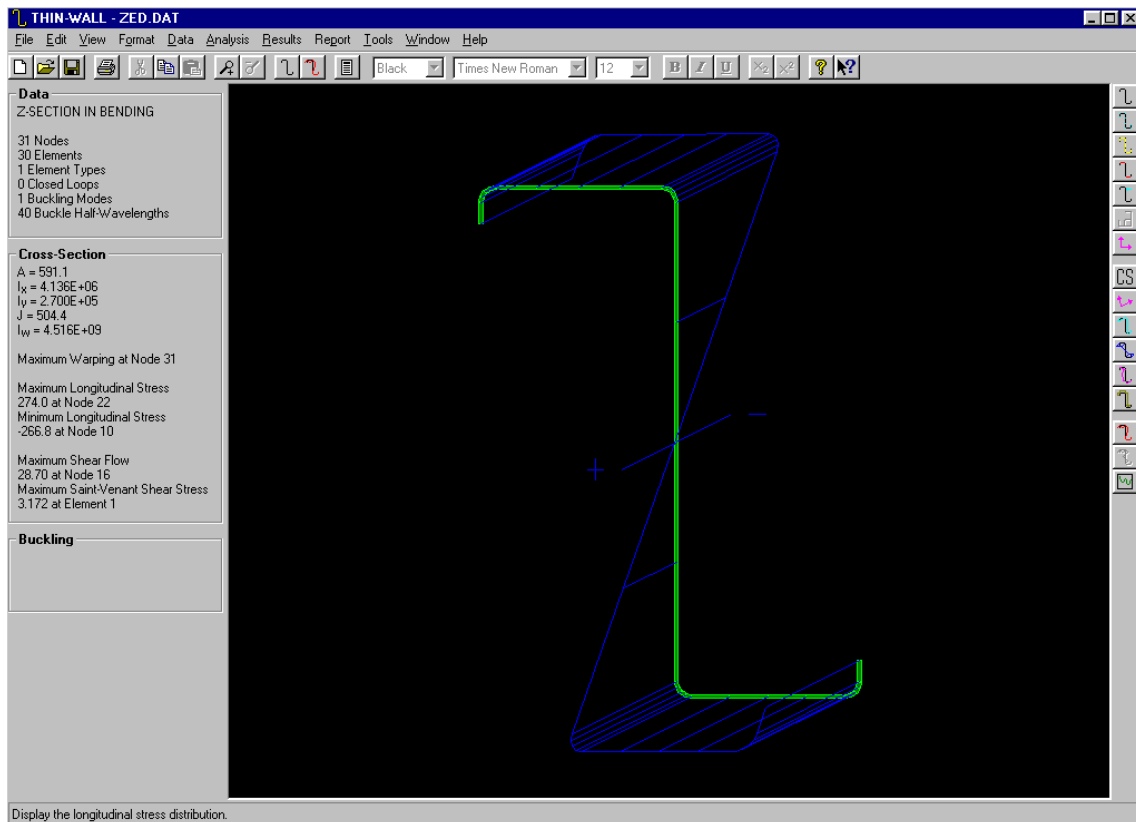
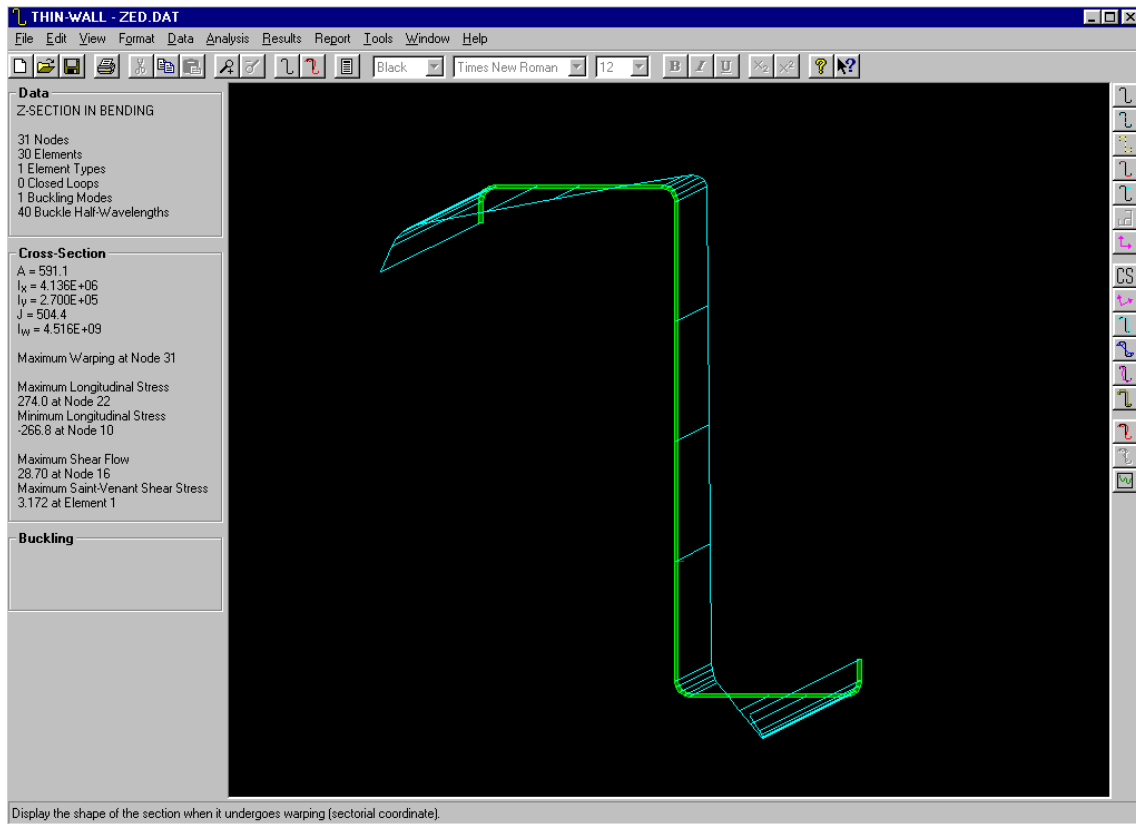

Finite Strip Buckling Analysis

The program THIN-WALL can also perform a buckling analysis of a thin-walled member under longitudinal stress using the finite strip method. The member must be uniform in thickness in the longitudinal direction and simply supported at its ends. The longitudinal edges may be simply supported, clamped or free along the full length of the member. The longitudinal stresses calculated by the cross-section analysis can be used for input in the finite strip buckling analysis. The buckling modes calculated by the analysis can be drawn on the screen and consequently the program is useful for demonstrating the different modes of buckling of thin-walled members. The buckling modes calculated include local, distortional and flexural-torsional buckling. For the example of a Z-section in bending, local buckling consists of deformation of the web, flange and lip elements without movement of the line junctions between the flange and web and the flange and lip stiffener. Distortional buckling consists of movement of the line junction between the flange and lip stiffener without a rigid body rotation or translation of the cross-section. The distortional buckling mode occurs at a significantly longer wavelength than the local buckling mode. At even longer wavelengths, the beam buckles in a flexural-torsional mode. The finite strip buckling analysis can be used to calculate more accurate values of local and distortional buckling stress than is available by simple hand methods. It is permissible in some design standards to use these more accurate values, and in some cases considerable economies can be achieved.

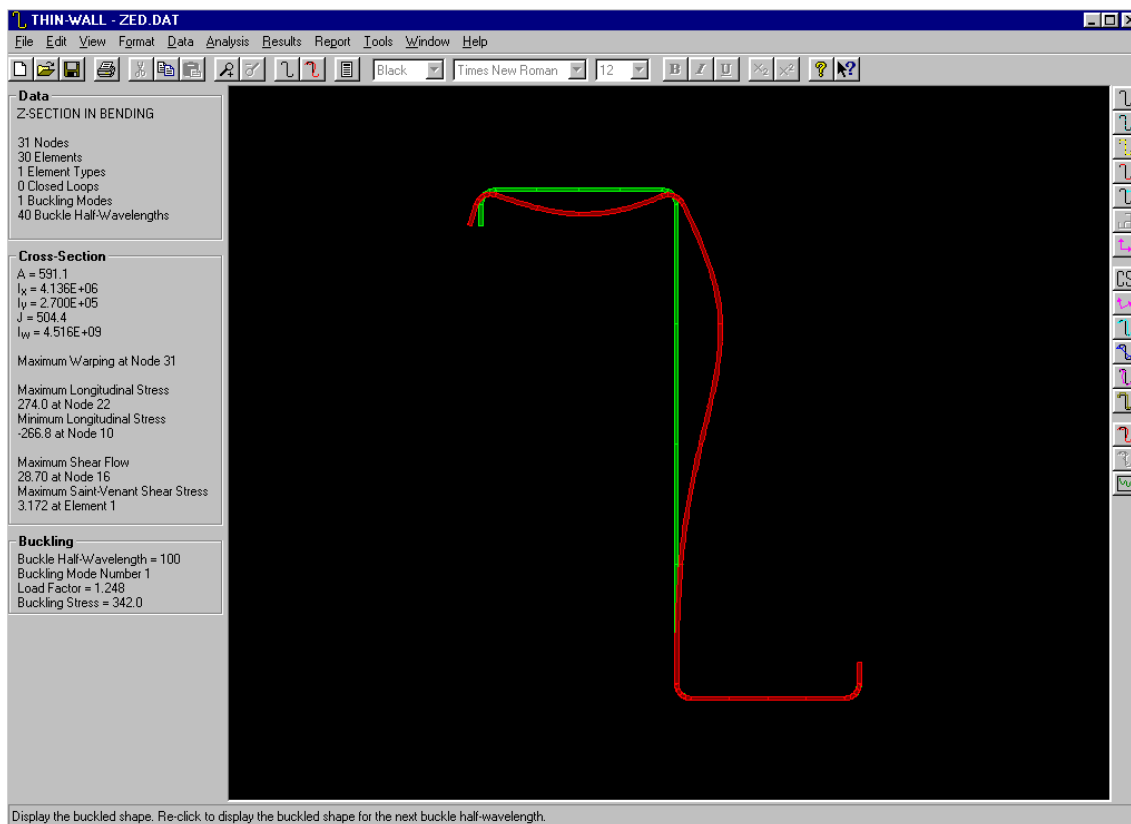

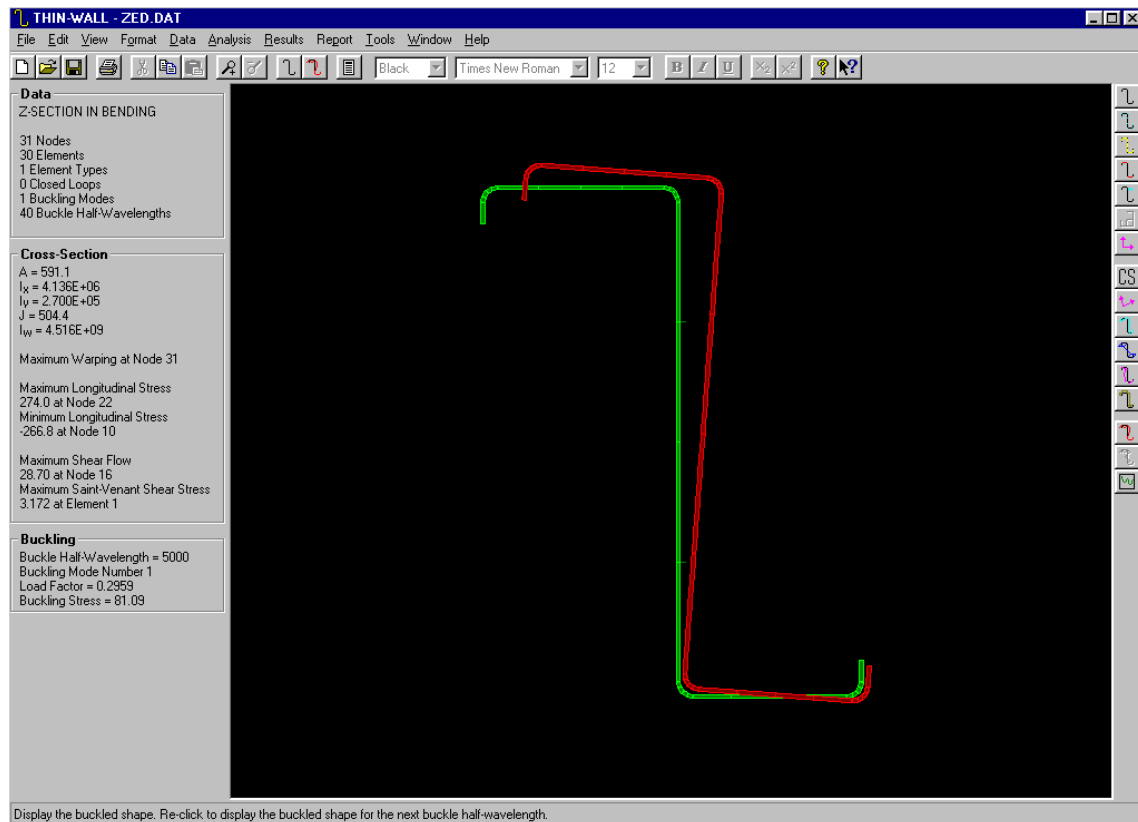
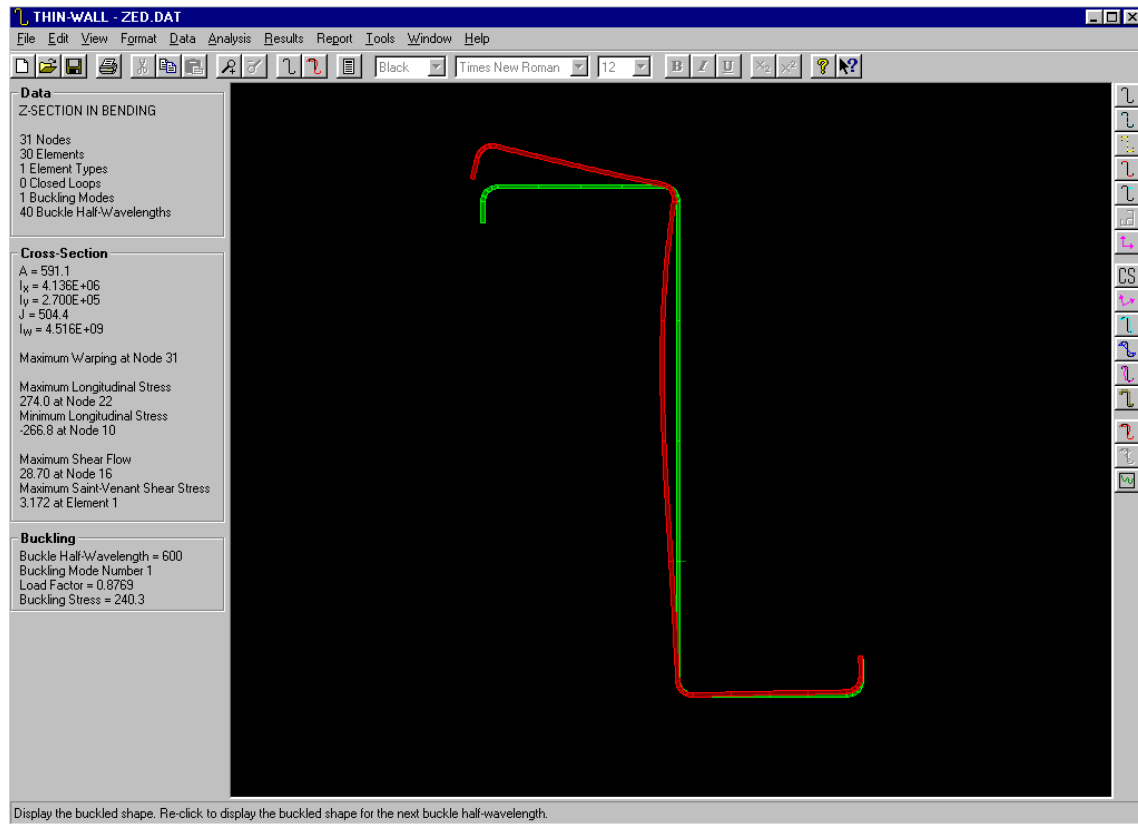

For the finite strip buckling analysis, the program does not distinguish between local, distortional or flexural-torsional modes. However, for short wavelength buckling modes such as local and distortional, where multiple half-wavelengths occur within the length of the folded plate system or member, then the analysis applies to one half-wavelength and the assumption of simply supported ends is usually valid at the ends of the half-wavelength being considered. Hence, the analysis must normally be repeated over a range of lengths corresponding to buckle half-wavelengths, especially for short wavelength buckling modes such as local and distortional.

THIN-WALL can draw a graph which shows the maximum stress in the section at buckling versus buckle half-wavelength for the half-wavelengths specified in the input data. For some members the distortional buckling stress can be lower than the local buckling stress, in which case distortional buckling will occur before local buckling if the member is long enough. Hence the distortional buckling mode becomes a serious consideration in the design of such members. This graph is also useful for structural engineers who wish to create new thin-walled sections under various loading. The cross-section shape of the new section (and hence the local and distortional buckling stress) can be adjusted by the engineer until the optimum solution is achieved.

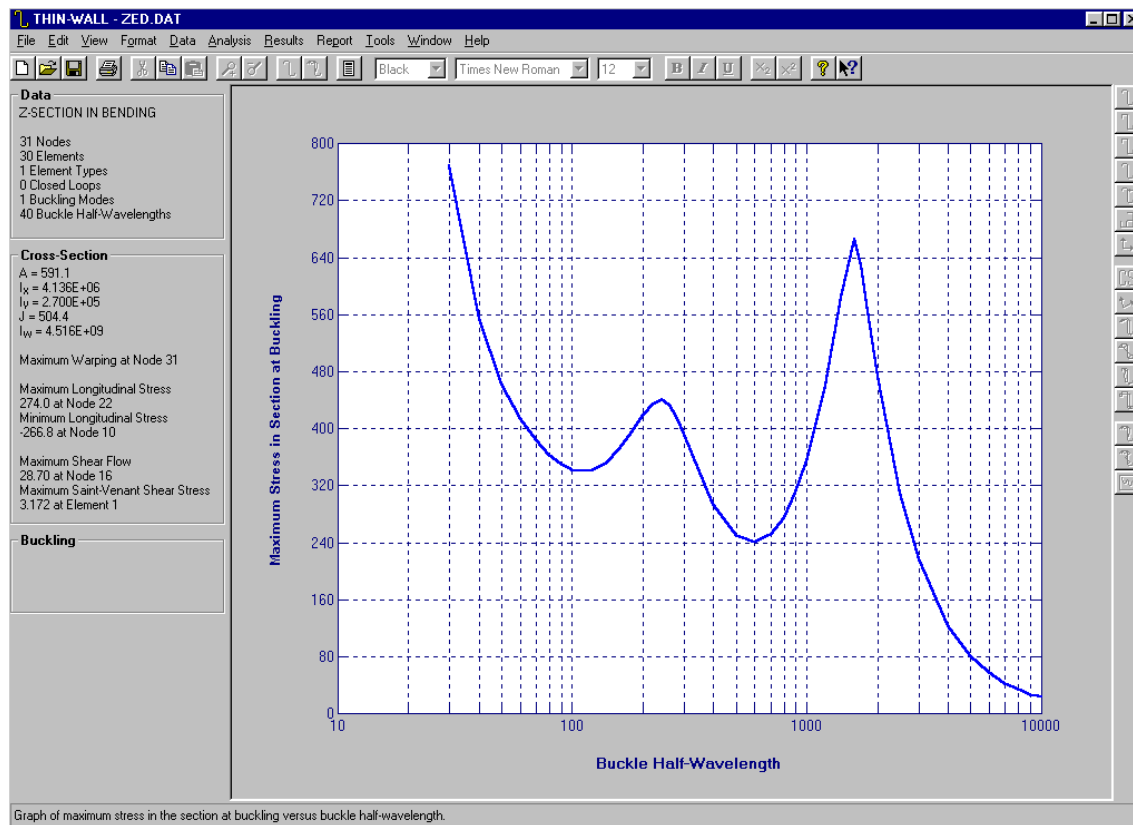

Direct Strength Method

THIN-WALL can calculate the axial force or moment design capacity of a member by the direct strength method. The program calculates the design capacities for local, distortional and flexural-torsional or overall buckling. The member design capacity is the lowest of these.

The direct strength method is an alternative to the effective width method in calculating the design capacity of a thin-walled member. The method uses the elastic buckling stresses calculated by THIN-



WALL with an appropriate strength curve to calculate the member design capacity. The direct strength method has the advantage that design calculations for complex sections are very simple, provided elastic buckling solutions are available.

The direct strength method will be described in Chapter 7 of the updated version of AS/NZS 4600 scheduled for release in 2004.

Report

THIN-WALL can generate a report which contains the data and results for the section. The report can also be edited from within THIN-WALL with the usual Windows commands such as Cut, Copy and Paste. The text colour, font type and size can also be changed. The user can also add comments to or delete certain parts of the report. The amount of information in the report can also be controlled. The report can either be printed from within THIN-WALL or saved to a file in rich text format. This file can be further edited using a sophisticated word-processing program such as Word.

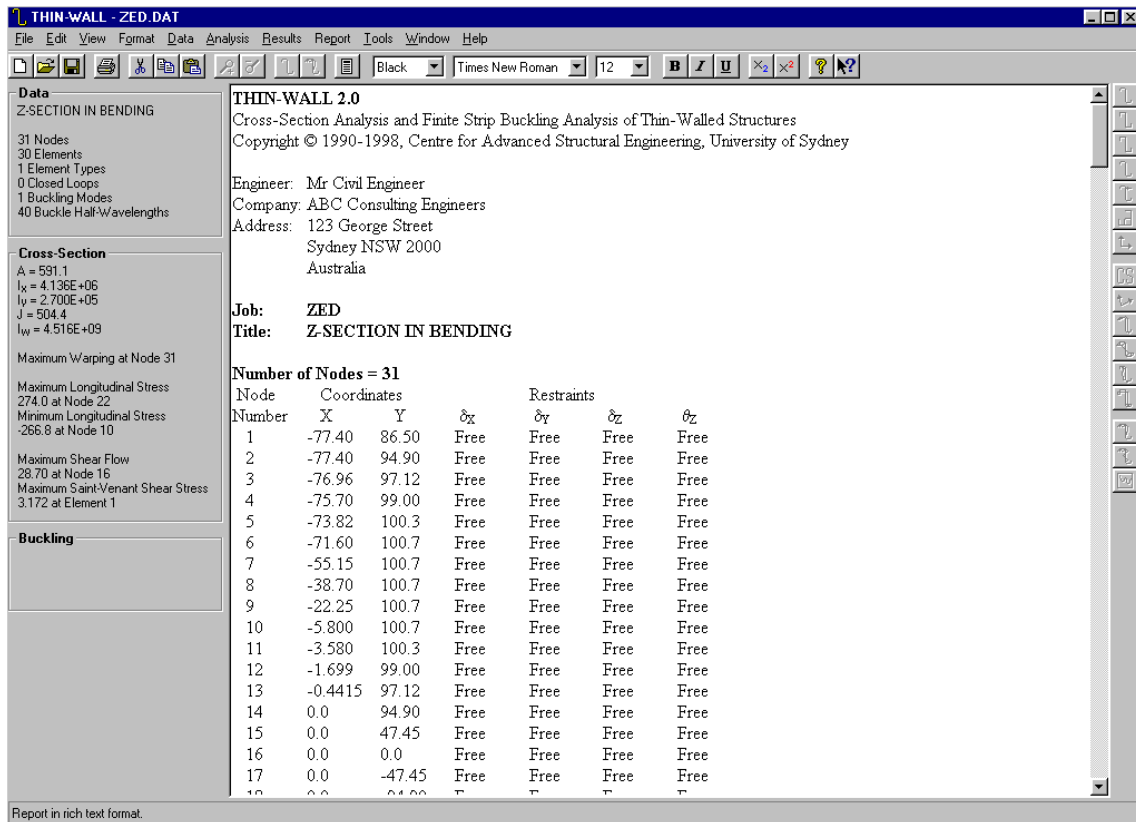

Zooming



THIN-WALL allows the user to zoom in and enlarge an area of the section. This feature is useful in checking the node and element data for sections with a large number of elements.

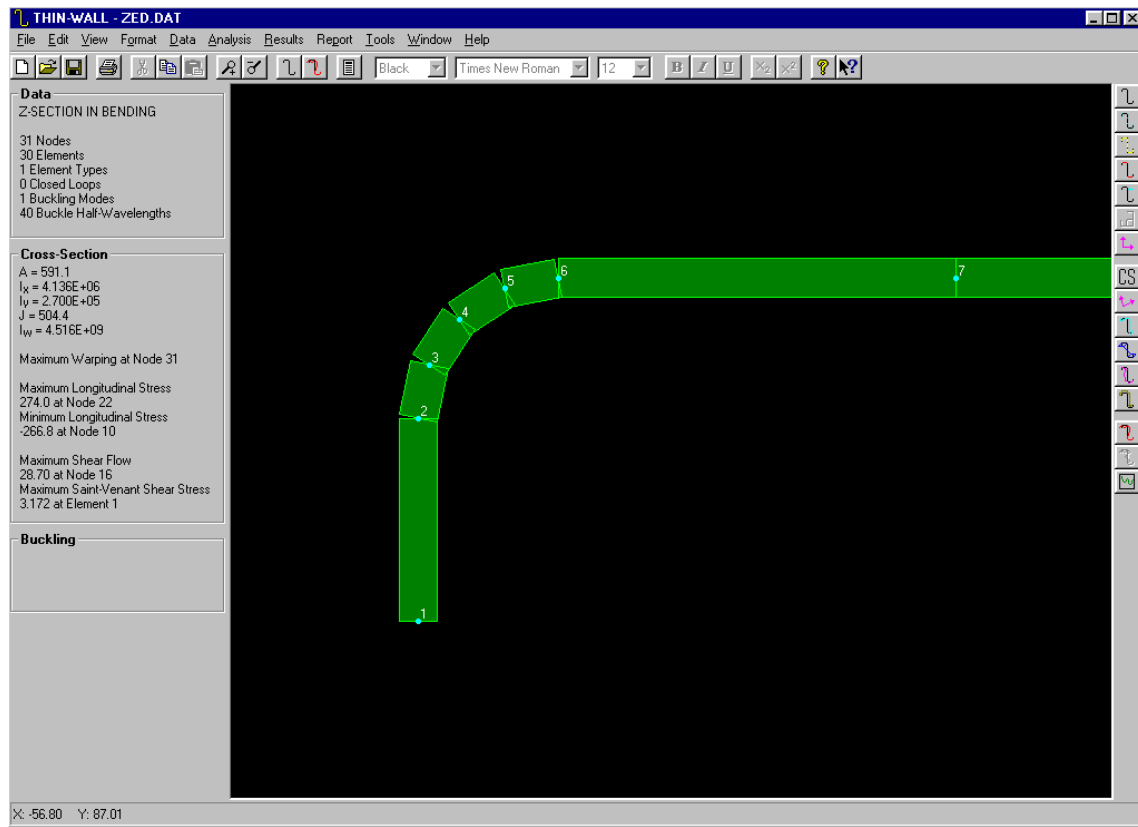

Colours and Lines

The appearance of the section and graph can be changed by adjusting the colours and lines. The entire Windows colour palette can be used as well as black and white colours for printing. THIN-WALL also allows the true thickness of the section to be drawn.

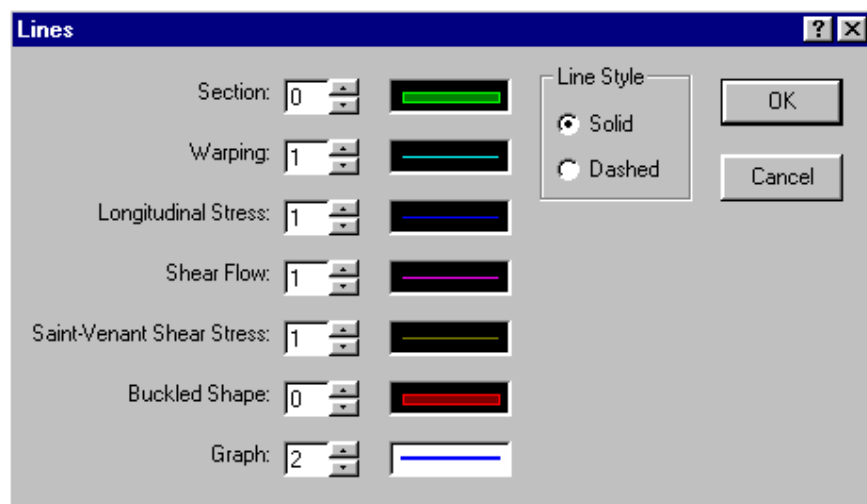
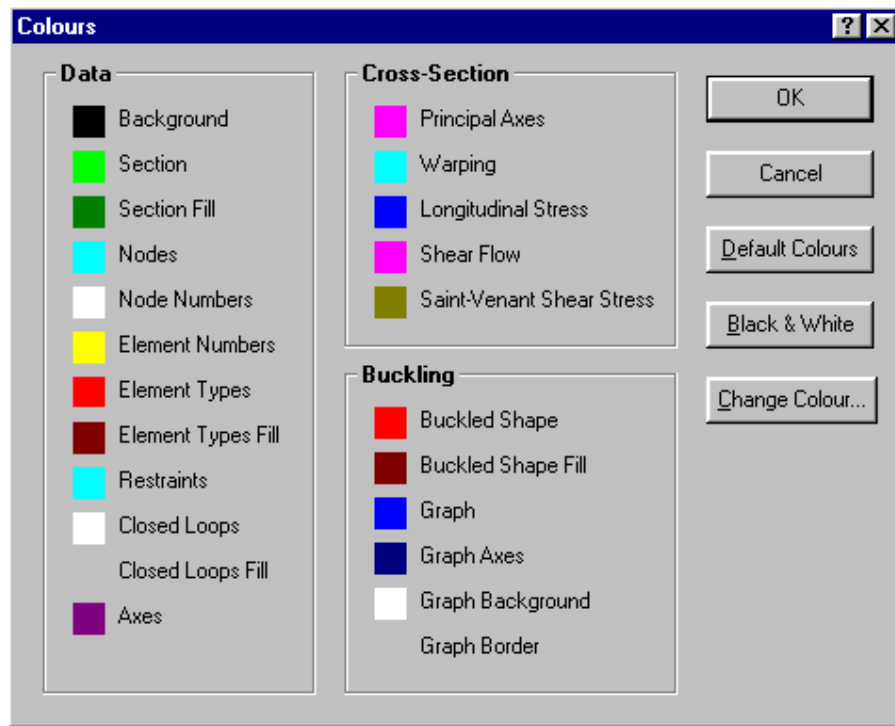



On-Line Help

THIN-WALL has a fully documented on-line help system like other Windows programs. This help system can be accessed through the help topics or pop-up help. The help topics include a table of contents, index and search facility, and act very much like an on-line users manual. When the question mark button at the top right corner of a form is clicked, the program allows the user to display pop-up help for a particular item. A tutorial is also available which shows a step-by-step guide on how to use THIN-WALL.

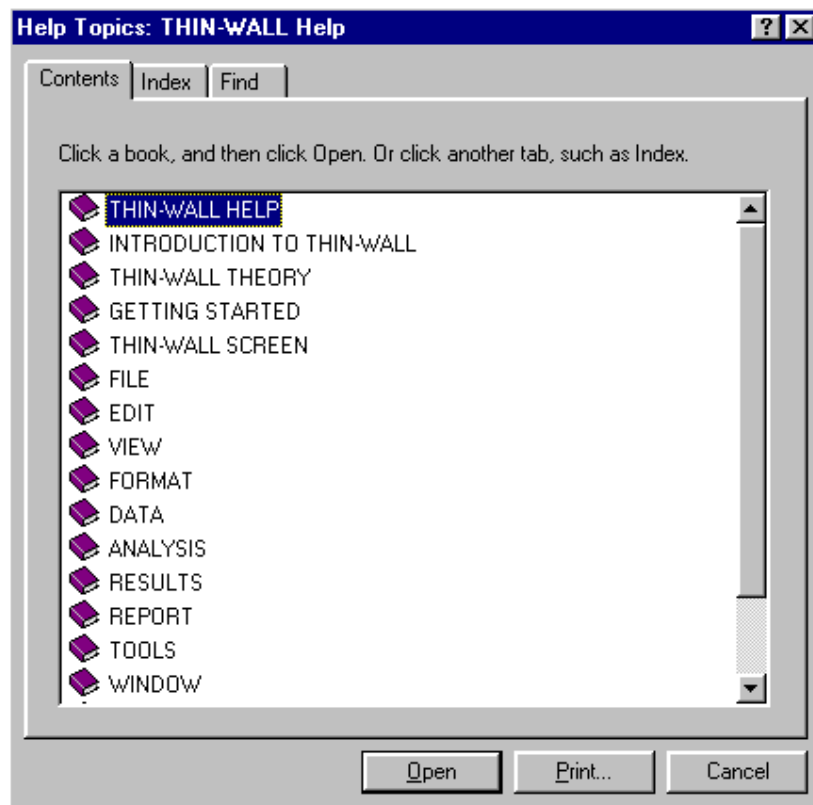



System Requirements

ThinWall has been developed to run under Windows 95/98/ME/NT/2000/XP.

Download a Demonstration Copy & Demo

Visit our website: <http://ww.civil.usyd.edu.au/case/software.shtml>

SALES INQUIRIES

Information about computer software and prices is available from:

Dr John Papangelis

Phone: 61 2 9351 3837

Fax: 61 2 9351 3343

Email: jpp@civil.usyd.edu.au